

SI SERIES INSIDE CORNERS

SAMPLE SPECIFICATION

specify as: SOFTFORMS® Model # SI-X-XXX

Pittcon SOFTFORMS®, LLC

6409 Rhode Island Avenue Riverdale, MD 20737 (800) 637-7638 (301) 927-1000 Fax: (301) 699-8690	3330 W. Flower Street Phoenix, AZ 85043 (800) 637-7638 (602) 233-9100 Fax: (602) 233-9400
--	---

The extruded aluminum profile shall incorporate a continuous integral fin for surface contact to conventionally installed gypsum drywall. The fins shall be 7/8" wide and shall be tapered to the edge. The tapered fins shall be punched with holes staggered to accept standard screw fastening. A series of continuous grooves shall be extruded into the face of the fins to provide greater bonding surface. The extruded profiles shall be primed with corrosion-resistant primer compatible with materials normally in use in conjunction with commercial interiors, i.e.: joint compound, latex and enamel paints, and wall covering adhesives.

MATERIAL: Aluminum alloy.....6063 T5 or equal
Finish.....Factory primed

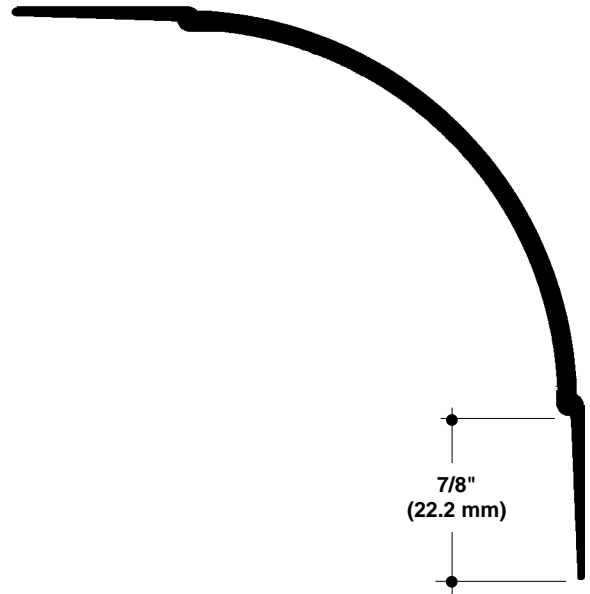

SI-9-200

INSIDE CORNER

NO SCALE

TYPICAL SECTION

SELECTING YOUR SOFTFORMS® SI SERIES OF ALUMINUM EXTRUSIONS

Select proper SOFTFORMS extrusion from the ordering information shown below.

Model Number	Radius
SI-9-075	3/4" (19.1 mm)
SI-9-100	1" (25.4 mm)
SI-9-150	1-1/2" (38.1 mm)
SI-9-200	2" (50.8 mm)
SI-9-250	2-1/2" (63.5 mm)
SI-9-300	3" (76.2 mm)
SI-9-400	4" (101.6 mm)

Note:

Special custom sizes are also available. Check with factory for availability and lead time.

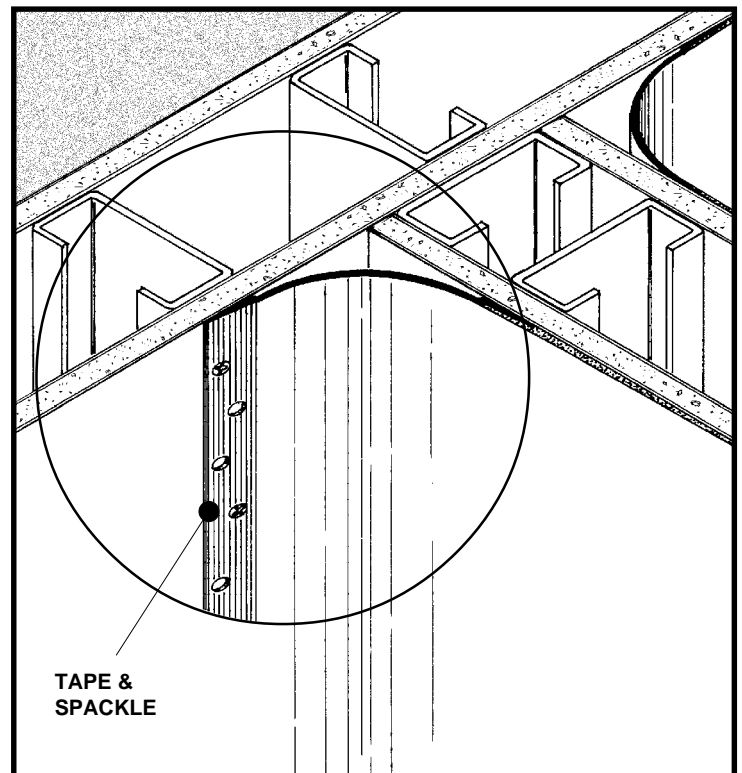

All details, methods and specifications are the exclusive property of Pittcon Softforms®, LLC. Pittcon reserves the right to change any specifications or details without prior notification. All Softforms® profiles are available in standard 10' lengths ±1/8" (2.048 M). Other lengths are available as special order items. For custom shapes, sizes, or for special finishes, please contact the factory or your nearest Pittcon sales representative.

© 2003 Pittcon SOFTFORMS®, LLC

Softforms®

PREFORMED ARCHITECTURAL PROFILES
FOR DRYWALL CONSTRUCTION

SI 67

SI SERIES INSIDE CORNERS

SELECTING YOUR SOFTFORMS® SI SERIES OF ALUMINUM EXTRUSIONS

Select proper SOFTFORMS® extrusion from the ordering information shown below.

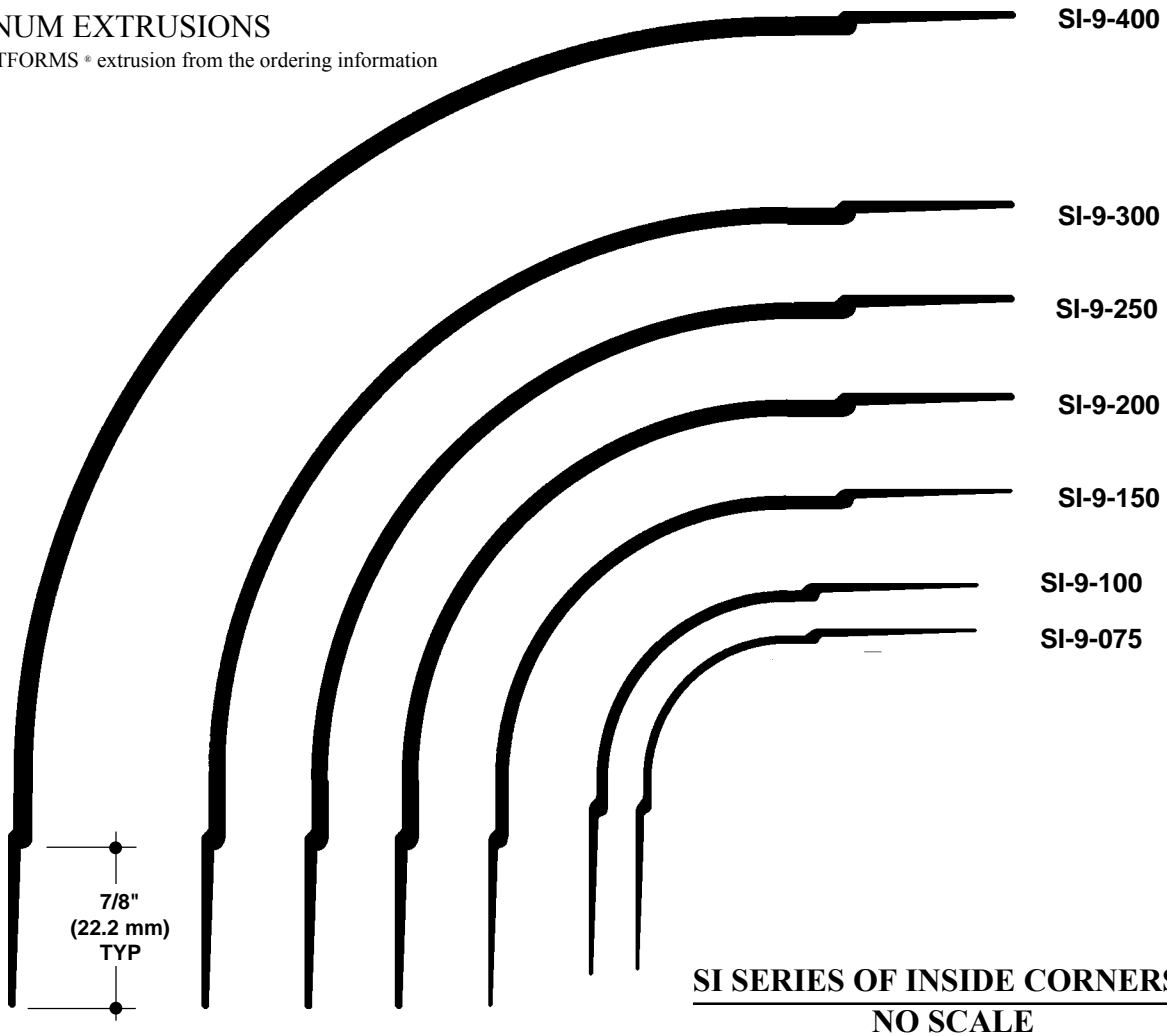

EXAMPLE DETAIL

For use with conventional metal stud construction and 1/2" or 5/8" GPDW.

The drawing below depicts the appropriate size, number, and placement of metal studs needed to accommodate the SI-9-200 inside corner and the corresponding SO-9-200 outside corner. The use of identical radii is recommended for both inside and outside corners when they appear in view of one another. Optional ceiling trims for acoustical tile support are available in either a pre-finished white or primed for field finishing. Screws through the grooved fins must always engage metal or wood substructure to ensure proper installation.

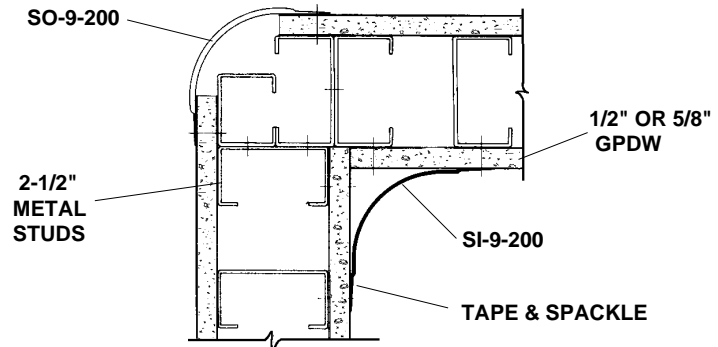

SI-9-200 + 2-1/2" STUD WALL

NO SCALE **TYPICAL**

Pittcon SOFTFORMS®, LLC

6409 Rhode Island Avenue
Riverdale, MD 20737
(800) 637-7638
(301) 927-1000
Fax: (301) 699-8690

3330 W. Flower Street
Phoenix, AZ 85043
(800) 637-7638
(602) 233-9100
Fax: (602) 233-9400

Softforms®
PREFORMED ARCHITECTURAL PROFILES
FOR DRYWALL CONSTRUCTION

SI-LRP

CUSTOM INSIDE CORNER With Perpendicular Fins

SAMPLE SPECIFICATION

specify as: SOFTFORMS® Model # SI-LRP

Pittcon SOFTFORMS®, LLC

6409 Rhode Island Avenue Riverdale, MD 20737 (800) 637-7638 (301) 927-1000 Fax: (301) 699-8690	3330 W. Flower Street Phoenix, AZ 85043 (800) 637-7638 (602) 233-9100 Fax: (602) 233-9400
--	---

The formed aluminum profile shall incorporate a continuous integral fin for surface contact to conventionally installed gypsum drywall. The formed profile shall be primed with corrosion-resistant primer compatible with materials normally in use in conjunction with commercial interiors, i.e.: joint compound, latex and enamel paints, and wall covering adhesives.

MATERIAL: Aluminum alloy.....3003 H-14 or equal
Finish.....Factory primed
Metal Thickness......090" typical

Note: Other thicknesses ranging from .062" to .125" are available upon request, with some restrictions applying. Check factory for your needs.

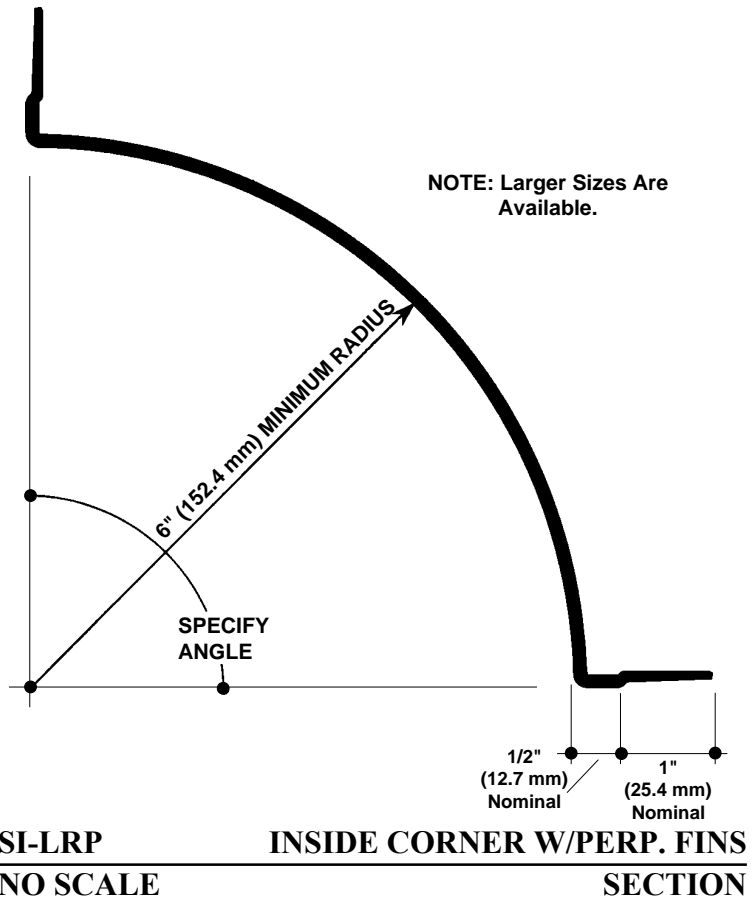

EXAMPLE DETAIL

For use with conventional metal stud construction and 1/2" or 5/8" GPDW.

The SI-LRP is a large radius inside corner or ceiling cove with perpendicular fins for corner drywall constructions similar to that depicted here. Screws through the installation fins must always engage metal or wood substructure to ensure proper installation.

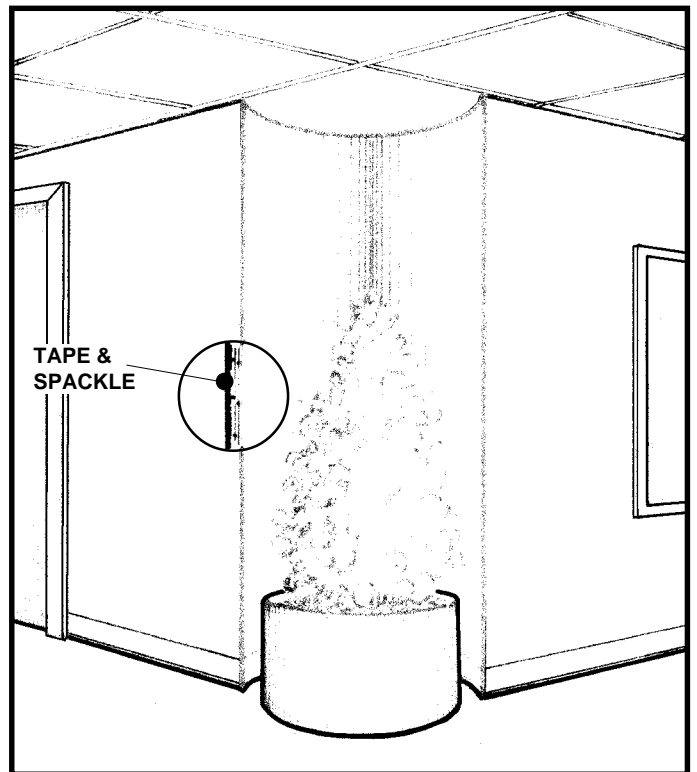
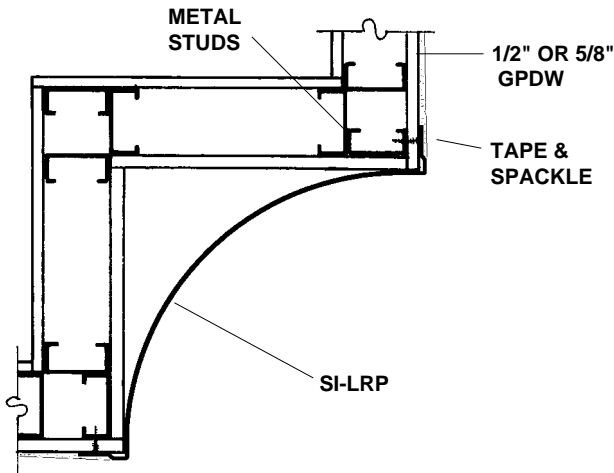

All details, methods and specifications are the exclusive property of Pittcon Softforms®, LLC. Pittcon reserves the right to change any specifications or details without prior notification. All Softforms® profiles are available in standard 10' lengths ±1/8" (2.048 M). Other lengths are available as special order items. For custom shapes, sizes, or for special finishes, please contact the factory or your nearest Pittcon sales representative.

© 2003 Pittcon SOFTFORMS®, LLC

Softforms®

PREFORMED ARCHITECTURAL PROFILES
FOR DRYWALL CONSTRUCTION

SI 69

SI-LRT

CUSTOM INSIDE CORNER With Tangential Fins

SAMPLE SPECIFICATION

specify as: SOFTFORMS® Model # SI-LRT

Pittcon SOFTFORMS®, LLC

6409 Rhode Island Avenue Riverdale, MD 20737 (800) 637-7638 (301) 927-1000 Fax: (301) 699-8690	3330 W. Flower Street Phoenix, AZ 85043 (800) 637-7638 (602) 233-9100 Fax: (602) 233-9400
--	---

The formed aluminum profile shall incorporate a continuous integral fin for surface contact to conventionally installed gypsum drywall. The formed profile shall be primed with corrosion-resistant primer compatible with materials normally in use in conjunction with commercial interiors, i.e.: joint compound, latex and enamel paints, and wall covering adhesives.

MATERIAL: Aluminum alloy.....3003 H-14 or equal
Finish.....Factory primed
Metal Thickness......090" typical

Note: Other thicknesses ranging from .062" to .125" are available upon request, with some restrictions applying. Check factory for your needs.

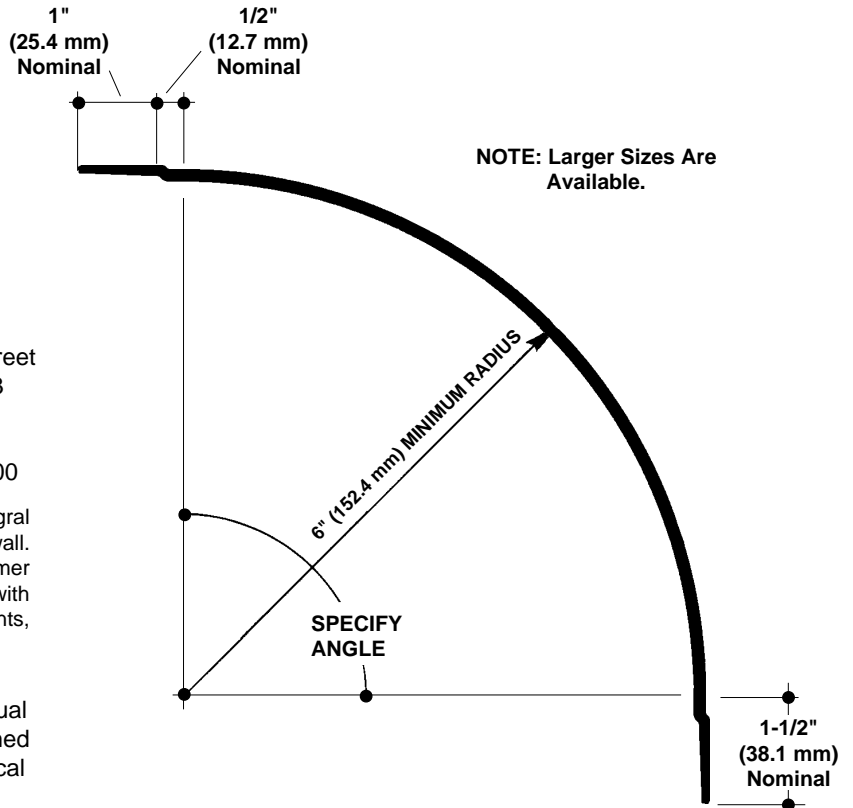

SI-LRT **INSIDE CORNER W/TANGENT FIN**
NO SCALE **SECTION**

EXAMPLE DETAIL

For use with conventional metal stud construction and 1/2" or 5/8" GPDW.

The SI-LRT is a large radius inside corner or ceiling cove with perpendicular fins for corner drywall constructions similar to that depicted here. Screws through the installation fins must always engage metal or wood substructure to ensure proper installation.

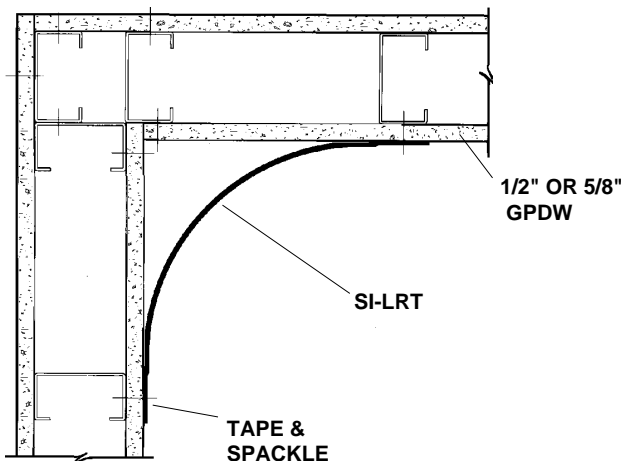

SI-LRT **STUD WALL**
NO SCALE **PLAN/SECTION**

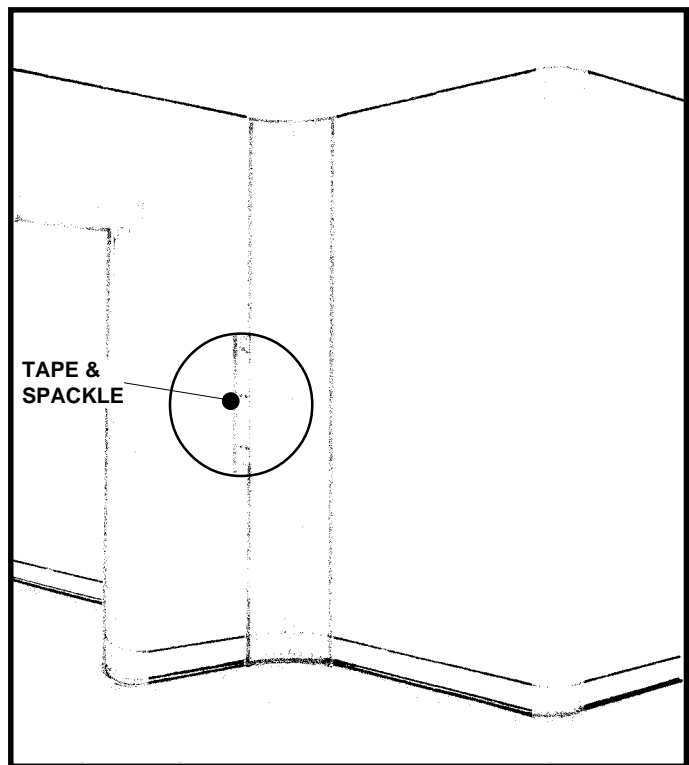

All details, methods and specifications are the exclusive property of Pittcon Softforms®, LLC. Pittcon reserves the right to change any specifications or details without prior notification. All Softforms® profiles are available in standard 10' lengths ±1/8" (2.048 M). Other lengths are available as special order items. For custom shapes, sizes, or for special finishes, please contact the factory or your nearest Pittcon sales representative.

© 2003 Pittcon SOFTFORMS®, LLC

Softforms®

PREFORMED ARCHITECTURAL PROFILES
FOR DRYWALL CONSTRUCTION

SI 70

SI-LRPT

CUSTOM INSIDE CORNER With One Perpendicular Fin

SAMPLE SPECIFICATION

specify as: SOFTFORMS® Model # SI-LRPT

Pittcon SOFTFORMS®, LLC

6409 Rhode Island Avenue Riverdale, MD 20737 (800) 637-7638 (301) 927-1000 Fax: (301) 699-8690	3330 W. Flower Street Phoenix, AZ 85043 (800) 637-7638 (602) 233-9100 Fax: (602) 233-9400
--	---

The formed aluminum profile shall incorporate a continuous integral fin for surface contact to conventionally installed gypsum drywall. The formed profile shall be primed with corrosion-resistant primer compatible with materials normally in use in conjunction with commercial interiors, i.e.: joint compound, latex and enamel paints, and wall covering adhesives.

MATERIAL: Aluminum alloy.....3003 H-14 or equal
Finish.....Factory primed
Metal Thickness......090" typical

Note: Other thicknesses ranging from .062" to .125" are available upon request, with some restrictions applying. Check factory for your needs.

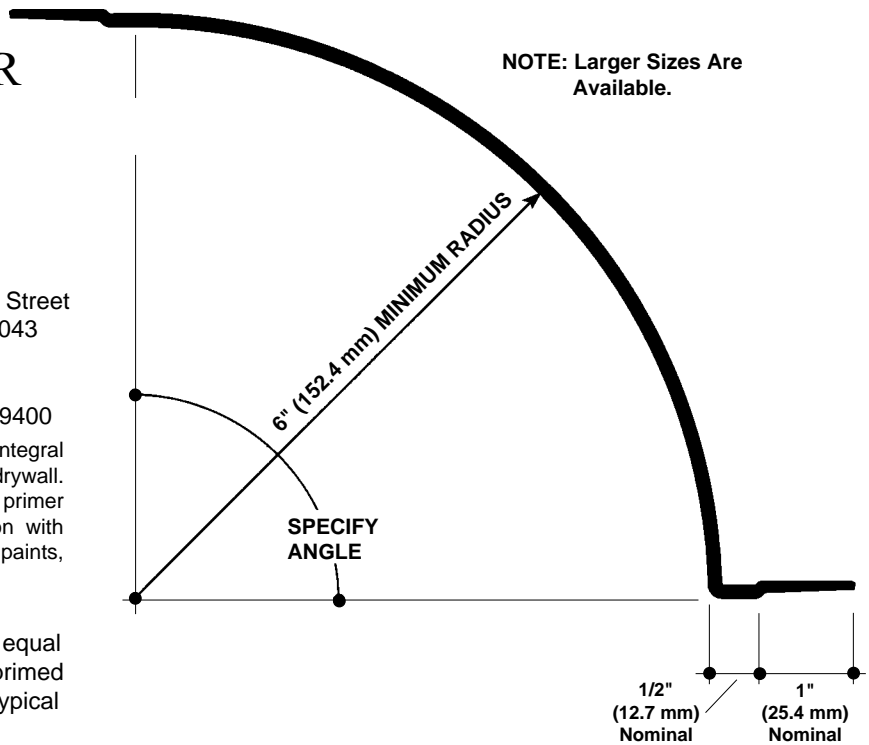

SI-LRPT

INSIDE CORNER

NO SCALE

W/ONE PERPENDICULAR FIN

EXAMPLE DETAIL

For use with conventional metal stud construction and 1/2" or 5/8" GPDW.

The SI-LRPT is a large radius inside corner or ceiling cove with perpendicular fins for corner drywall constructions similar to that depicted here. Screws through the grooved fins must always engage metal or wood substructure to ensure proper installation.

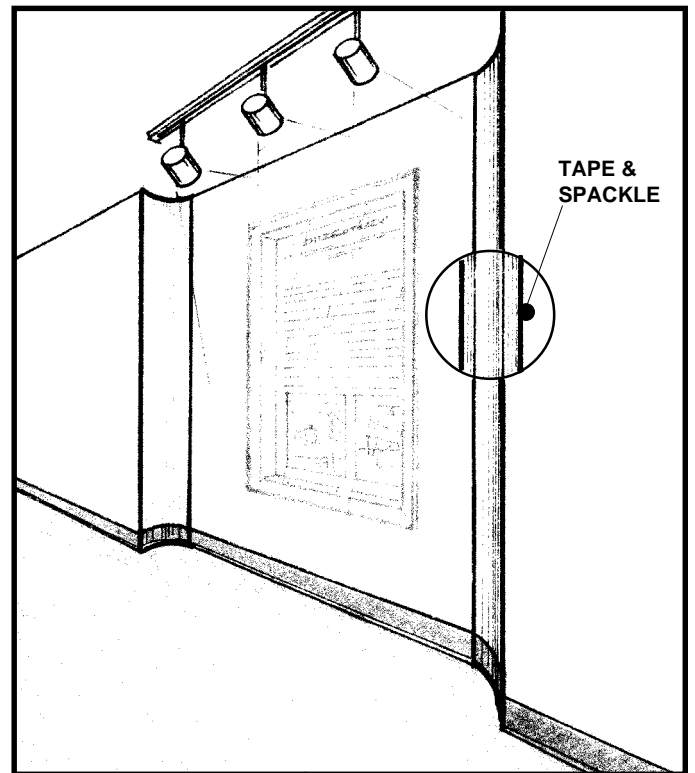
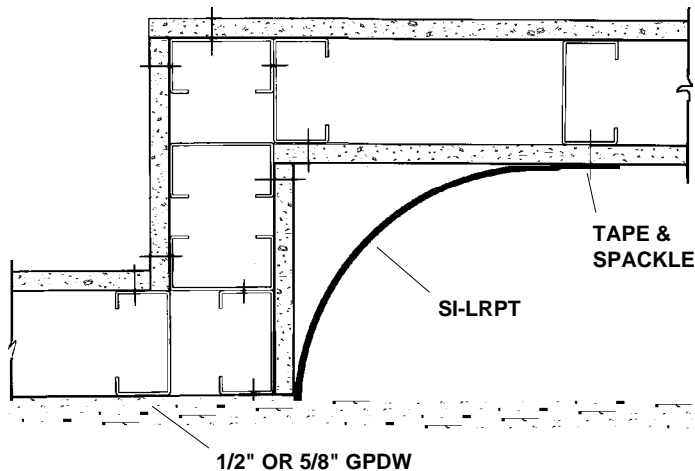

SI-LRPT CUSTOM CORNER

NO SCALE

PLAN/SECTION

All details, methods and specifications are the exclusive property of Pittcon Softforms®, LLC. Pittcon reserves the right to change any specifications or details without prior notification. All Softforms® profiles are available in standard 10' lengths ±1/8" (2.048 M). Other lengths are available as special order items. For custom shapes, sizes, or for special finishes, please contact the factory or your nearest Pittcon sales representative.

© 2003 Pittcon SOFTFORMS®, LLC

Softforms®

PREFORMED ARCHITECTURAL PROFILES
FOR DRYWALL CONSTRUCTION

SI 71

SI/SO-LRT

CUSTOM INSIDE/OUTSIDE CORNER SET

SAMPLE SPECIFICATION

specify as: SOFTFORMS® Model # SI/SO-LRT

Pittcon SOFTFORMS®, LLC

6409 Rhode Island Avenue Riverdale, MD 20737 (800) 637-7638 (301) 927-1000 Fax: (301) 699-8690	3330 W. Flower Street Phoenix, AZ 85043 (800) 637-7638 (602) 233-9100 Fax: (602) 233-9400
--	---

The formed aluminum profile shall incorporate a continuous integral fin for surface contact to conventionally installed gypsum drywall. The formed profile shall be primed with corrosion-resistant primer compatible with materials normally in use in conjunction with commercial interiors, i.e.: joint compound, latex and enamel paints, and wall covering adhesives.

MATERIAL: Aluminum alloy.....3003 H-14 or equal
Finish.....Factory primed
Metal Thickness......090" typical

Note: Other thicknesses ranging from .062" to .125" are available upon request, with some restrictions applying. Check factory for your needs.

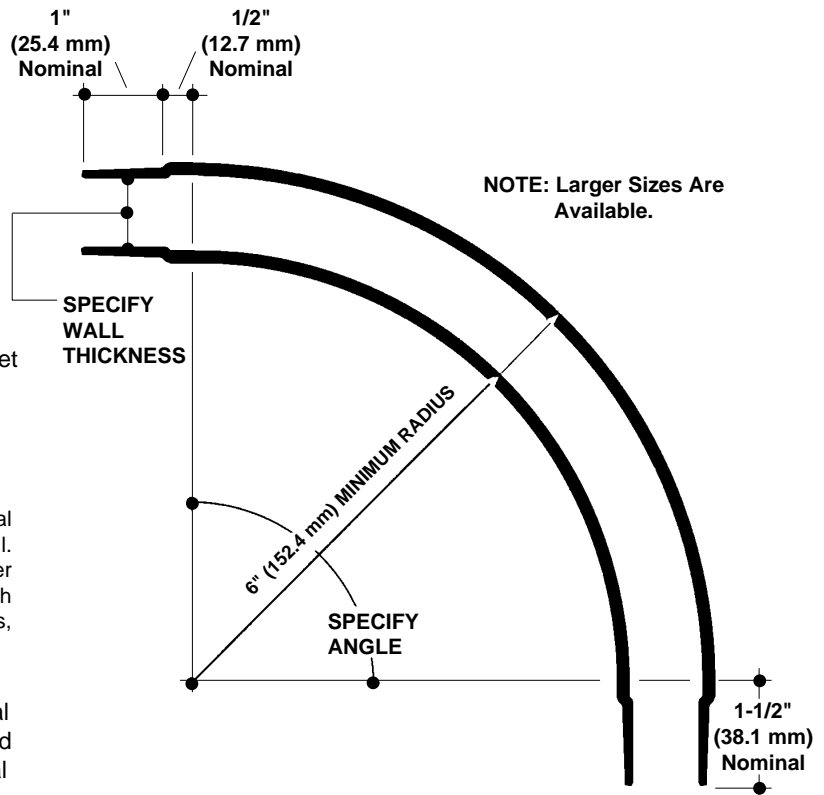

SI/SO-LRT
NO SCALE

INSIDE/OUTSIDE CORNER SET
SECTION

EXAMPLE DETAIL

For use with conventional metal stud construction and 1/2" or 5/8" GPDW.

The SI/SO-LRT set is a constant thickness inside/outside corner for drywall constructions similar to that depicted here. Screws through the installation fins must always engage metal or wood substructure to ensure proper installation.

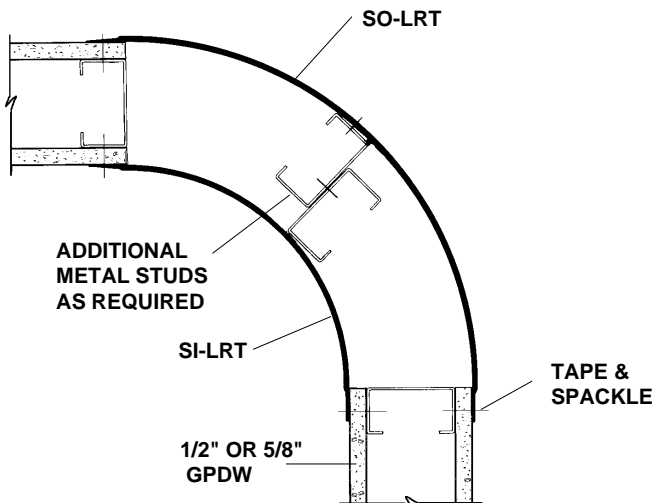

SI/SO-LRT
NO SCALE

STUD WALL
PLAN/SECTION

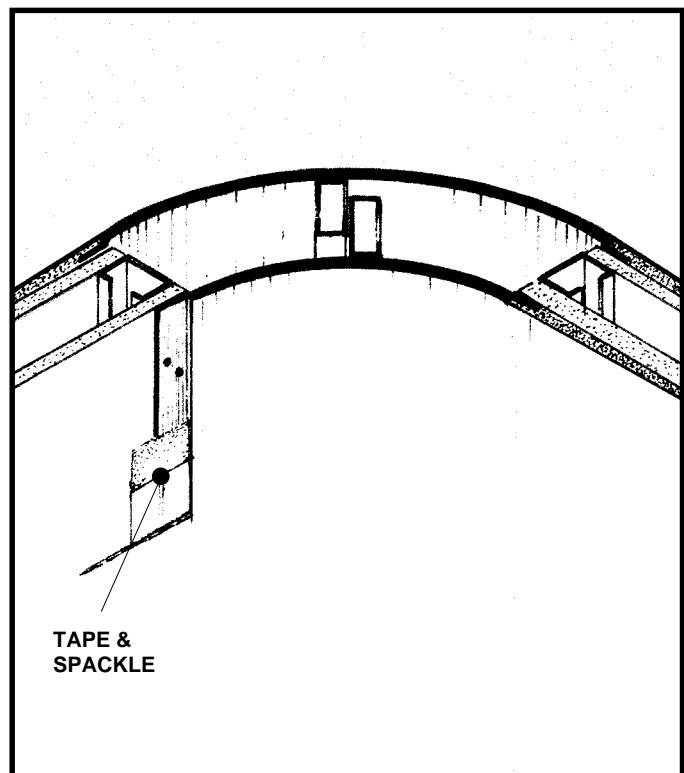

All details, methods and specifications are the exclusive property of Pittcon Softforms®, LLC. Pittcon reserves the right to change any specifications or details without prior notification. All Softforms® profiles are available in standard 10' lengths ±1/8" (2.048 M). Other lengths are available as special order items. For custom shapes, sizes, or for special finishes, please contact the factory or your nearest Pittcon sales representative.

© 2003 Pittcon SOFTFORMS®, LLC

Softforms®

PREFORMED ARCHITECTURAL PROFILES
FOR DRYWALL CONSTRUCTION

SI 72