

# VPT SERIES VENEER T-MOLDING

Specify as: Pittcon Plaster Molding

Model No. VPT-xx-xxx

MATERIAL: Aluminum alloy.....6063 T5  
 Finish.....Clear Anodized  
 Thickness......050" nominal

Many optional finishes are available. Consult factory for pricing and availability. Finishes meet or exceed AAMA standards for scratches or blemishes.

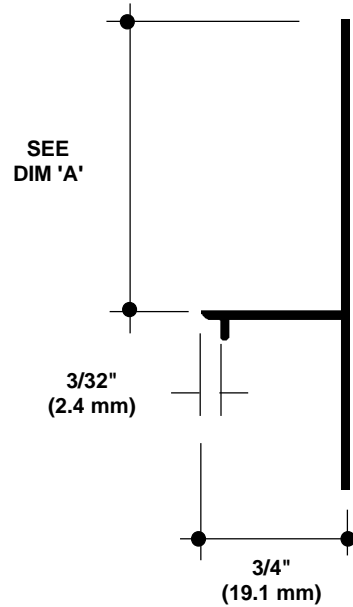

NO SCALE

TYPICAL SECTION

Model No.	Width-Dim 'A'	Depth
VPT-75-50	1/2" (12.7mm)	3/4" (19.1mm)
VPT-75-75	3/4" (19.1mm)	3/4" (19.1mm)
VPT-75-100	1" (25.1mm)	3/4" (19.1mm)
VPT-75-150	1-1/2" (38.1mm)	3/4" (19.1mm)

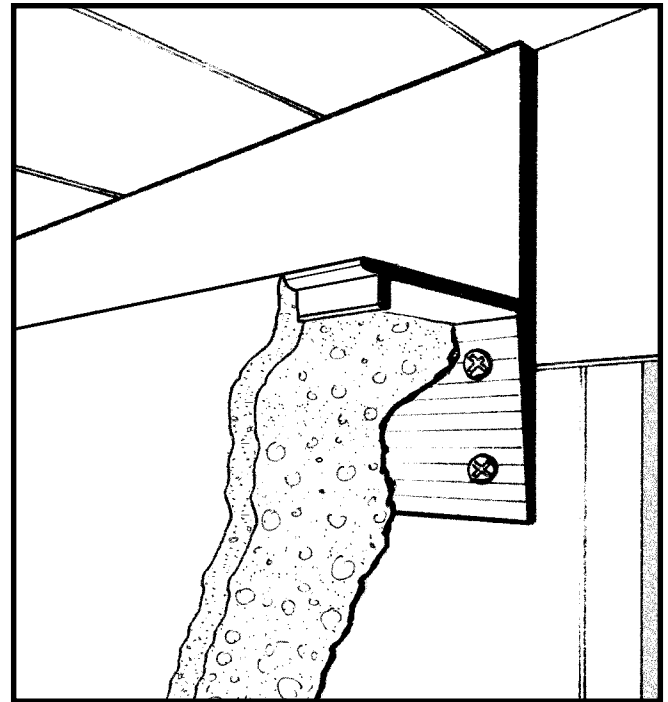

©2003 Pittcon Industries

*West*

17070 Green Drive  
 City of Industry, CA 91745  
 Phone: (626) 839-9100  
 Fax: (626) 839-0258

3330 W. Flower Street  
 Phoenix, AZ 85017  
 Phone: (602) 233-9100  
 Fax: (602) 233-9400

**Pittcon  
 Industries**

DIVISION OF PITTCO ARCHITECTURAL METALS, LLC

**800 637-7638**

*East*

6409 Rhode Island Ave.  
 Riverdale, MD 20737  
 Phone: (301) 927-1000  
 Fax: (301) 699-8690

# VPC SERIES

## VENEER CHANNEL SCREED

Specify as: Pittcon Plaster Molding

Model No. VPC-xx-xxx

MATERIAL: Aluminum alloy.....6063 T5  
 Finish.....Clear Anodized  
 Thickness......050" nominal

Many optional finishes are available. Consult factory for pricing and availability. Finishes meet or exceed AAMA standards for scratches or blemishes.

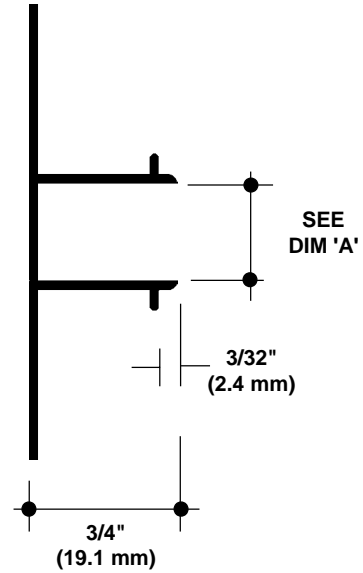

NO SCALE

TYPICAL SECTION

Model No.	Width-Dim 'A'	Depth
VPC-75-50	1/2" (12.7mm)	3/4" (19.1mm)
VPC-75-75	3/4" (19.1mm)	3/4" (19.1mm)

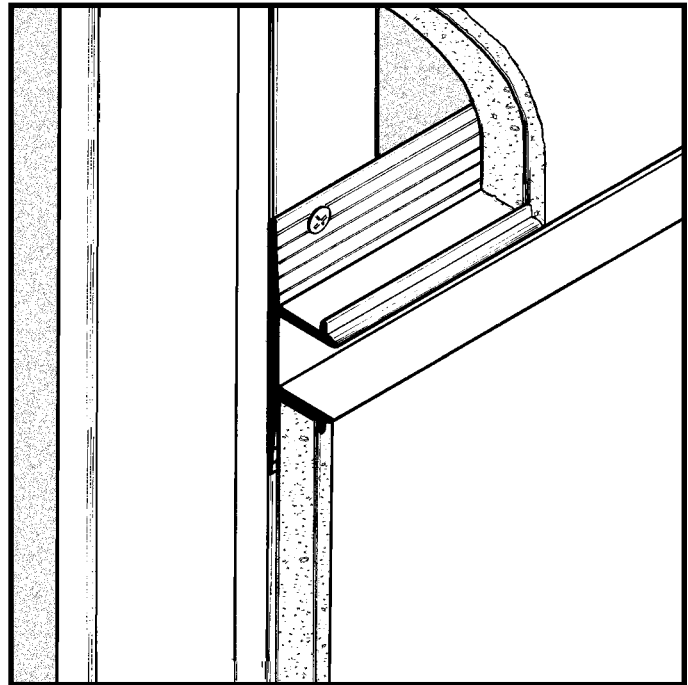

© 2003 Pittcon Industries

*West*

17070 Green Drive  
 City of Industry, CA 91745  
 Phone: (626) 839-9100  
 Fax: (626) 839-0258

3330 W. Flower Street  
 Phoenix, AZ 85017  
 Phone: (602) 233-9100  
 Fax: (602) 233-9400

**Pittcon Industries**

DIVISION OF PITTCOON ARCHITECTURAL METALS, LLC

800 637-7638

*East*

6409 Rhode Island Ave.  
 Riverdale, MD 20737  
 Phone: (301) 927-1000  
 Fax: (301) 699-8690

# VPR 75-38/38

## VENEER CHANNEL SCREED

Specify as: Pittcon Plaster Molding

Model No. VPR 75-38/38

MATERIAL: Aluminum alloy.....6063 T5  
 Finish.....Clear Anodized  
 Thickness......050" nominal

Many optional finishes are available. Consult factory for pricing and availability. Finishes meet or exceed AAMA standards for scratches or blemishes.

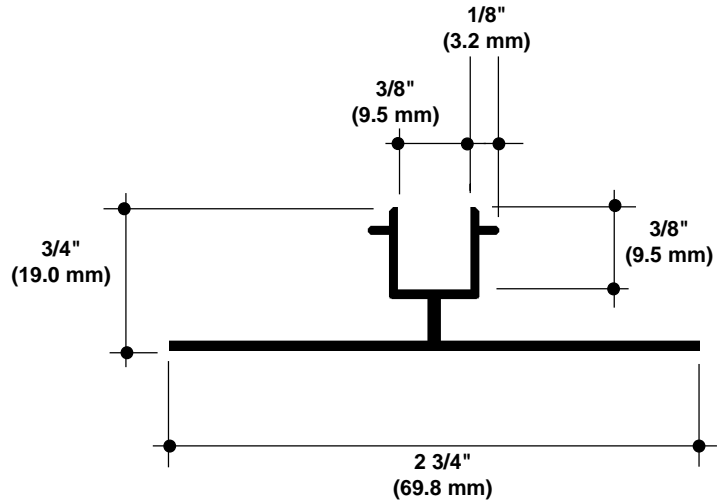

NO SCALE

TYPICAL SECTION

Model No.	Width	Depth
VPR 75-38/38	3/8" (9.5mm)	3/8" (9.5mm)

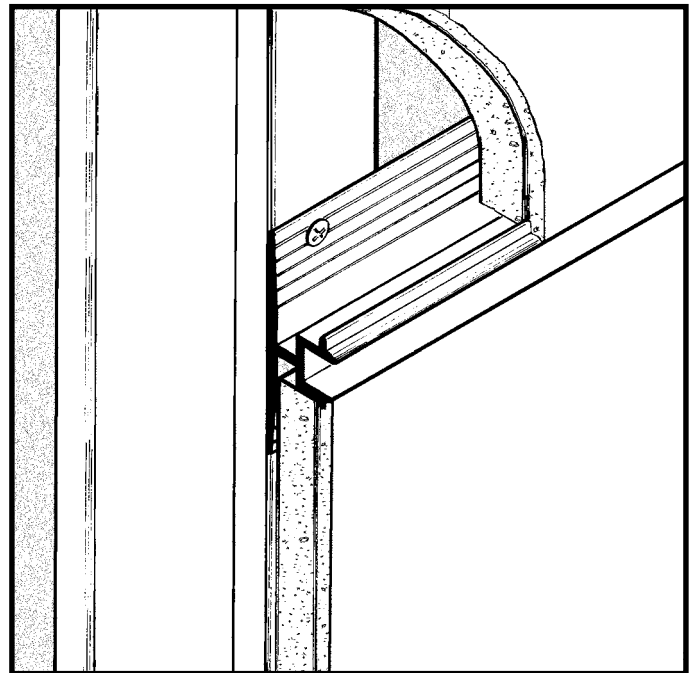

© 2003 Pittcon Industries

*West*

17070 Green Drive  
 City of Industry, CA 91745  
 Phone: (626) 839-9100  
 Fax: (626) 839-0258

3330 W. Flower Street  
 Phoenix, AZ 85017  
 Phone: (602) 233-9100  
 Fax: (602) 233-9400

**Pittcon Industries**

DIVISION OF PITTCON ARCHITECTURAL METALS, LLC

800 637-7638

*East*

6409 Rhode Island Ave.  
 Riverdale, MD 20737  
 Phone: (301) 927-1000  
 Fax: (301) 699-8690

# VPCB-75-75

## CORNER MOLD

Specify as: Pittcon Plaster Molding

Model No. VPCB-75-75

MATERIAL: Aluminum alloy.....6063 T5  
 Finish.....Clear Anodized  
 Thickness......050" nominal

Many optional finishes are available. Consult factory for pricing and availability. Finishes meet or exceed AAMA standards for scratches or blemishes.

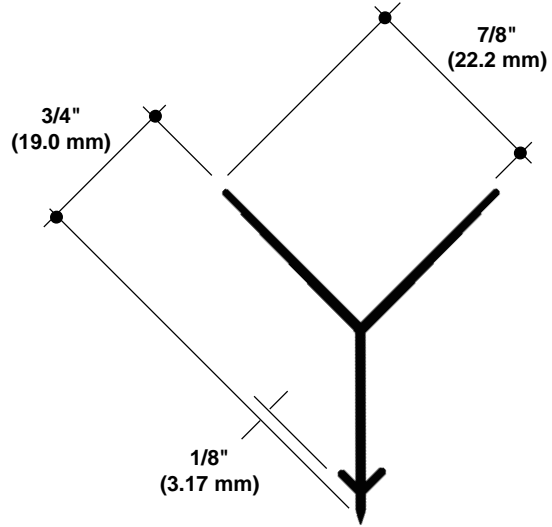

NO SCALE

TYPICAL SECTION

Model No.	Width	Depth
VPCB-75-75	3/4" (19.1mm)	3/4" (19.1mm)

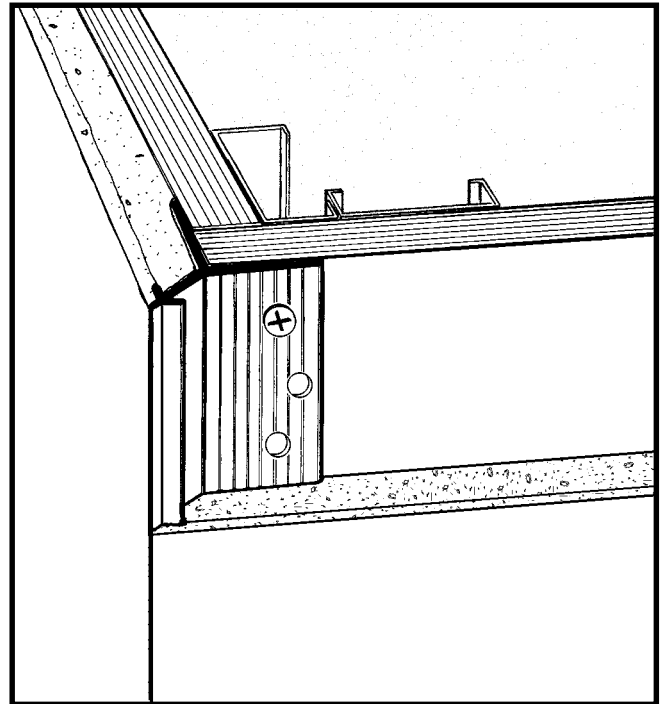

©2003 Pittcon Industries



17070 Green Drive  
 City of Industry, CA 91745  
 Phone: (626) 839-9100  
 Fax: (626) 839-0258

3330 W. Flower Street  
 Phoenix, AZ 85017  
 Phone: (602) 233-9100  
 Fax: (602) 233-9400

**Pittcon Industries**

DIVISION OF PITTCOON ARCHITECTURAL METALS, LLC

800 637-7638



6409 Rhode Island Ave.  
 Riverdale, MD 20737  
 Phone: (301) 927-1000  
 Fax: (301) 699-8690

# VPFC-075

## FLUSH CORNER MOLDING

Specify as: Pittcon Plaster Molding

Model No. VPFC-075

MATERIAL: Aluminum alloy.....6063 T5  
 Finish.....Clear Anodized  
 Thickness......050" nominal

Many optional finishes are available. Consult factory for pricing and availability. Finishes meet or exceed AAMA standards for scratches or blemishes.

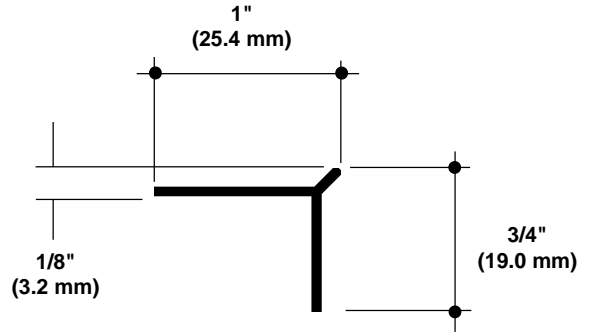

NO SCALE

TYPICAL SECTION

Model No.	Depth
VPFC-075	3/4" (19.1mm)

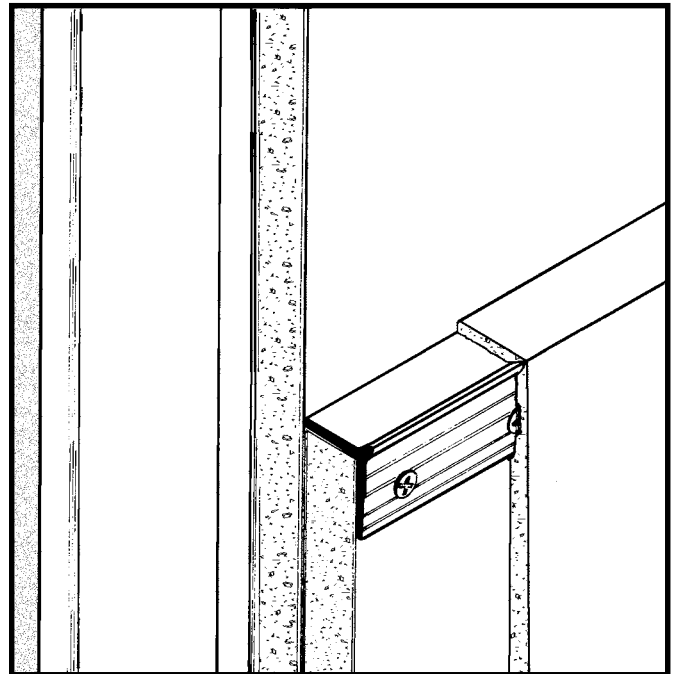

© 2003 Pittcon Industries

*West*

17070 Green Drive  
 City of Industry, CA 91745  
 Phone: (626) 839-9100  
 Fax: (626) 839-0258

3330 W. Flower Street  
 Phoenix, AZ 85017  
 Phone: (602) 233-9100  
 Fax: (602) 233-9400

**Pittcon Industries**

DIVISION OF PITTCON ARCHITECTURAL METALS, LLC

800 637-7638

*East*

6409 Rhode Island Ave.  
 Riverdale, MD 20737  
 Phone: (301) 927-1000  
 Fax: (301) 699-8690

# VPTR-38-38

## TRIM REVEAL MOLDING

Specify as: Pittcon Plaster Molding

Model No. VPTR-38-38

MATERIAL: Aluminum alloy.....6063 T5  
 Finish.....Clear Anodized  
 Thickness......050" nominal

Many optional finishes are available. Consult factory for pricing and availability. Finishes meet or exceed AAMA standards for scratches or blemishes.

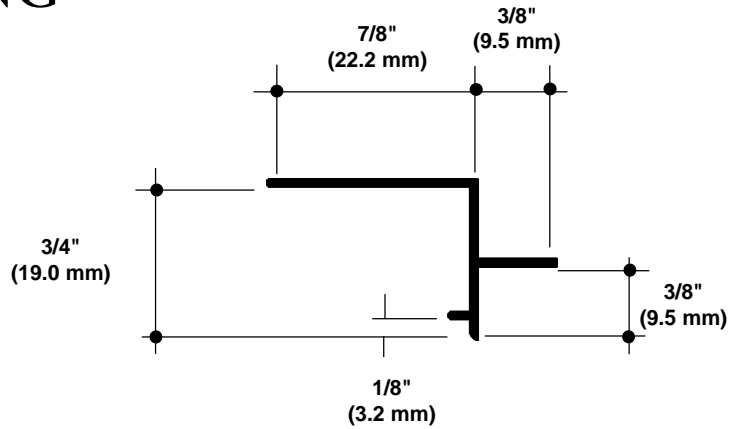

NO SCALE TYPICAL SECTION

Model No.	Width	Depth
VPTR-38-38	3/8" (9.5mm)	3/8" (9.5mm)

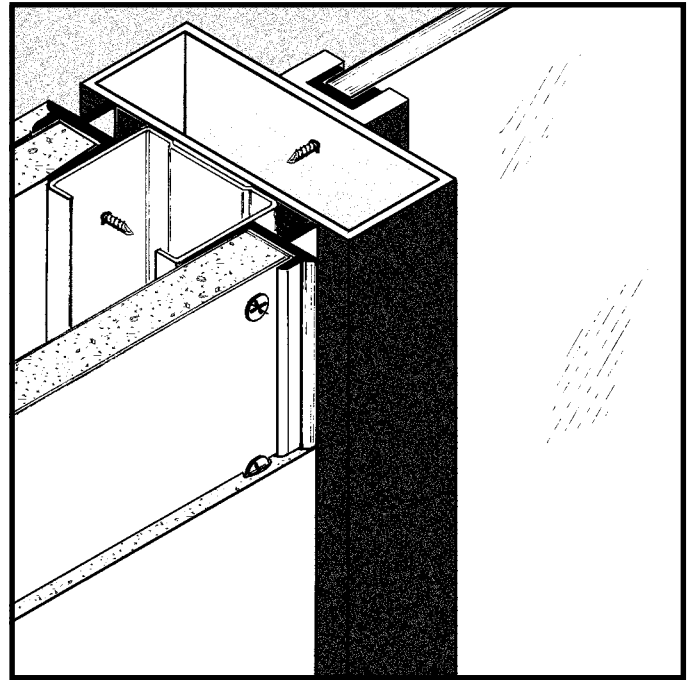

© 2003 Pittcon Industries

*West*

17070 Green Drive  
 City of Industry, CA 91745  
 Phone: (626) 839-9100  
 Fax: (626) 839-0258

3330 W. Flower Street  
 Phoenix, AZ 85017  
 Phone: (602) 233-9100  
 Fax: (602) 233-9400

**Pittcon Industries**

DIVISION OF PITTCO ARCHITECTURAL METALS, LLC

800 637-7638

*East*

6409 Rhode Island Ave.  
 Riverdale, MD 20737  
 Phone: (301) 927-1000  
 Fax: (301) 699-8690

# VPCP-050 TRANSITION MOLD

Specify as: Pittcon Plaster Molding

Model No. VPCP-050

MATERIAL: Aluminum alloy.....6063 T5  
 Finish.....Clear Anodized  
 Thickness......050" nominal

Many optional finishes are available. Consult factory for pricing and availability. Finishes meet or exceed AAMA standards for scratches or blemishes.

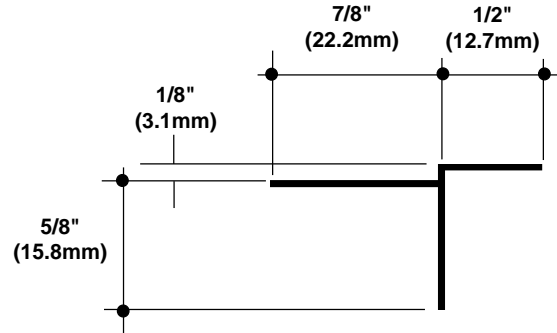

NO SCALE

TYPICAL SECTION

Model No.	Width
VPCP-050	1/2" (12.7mm)

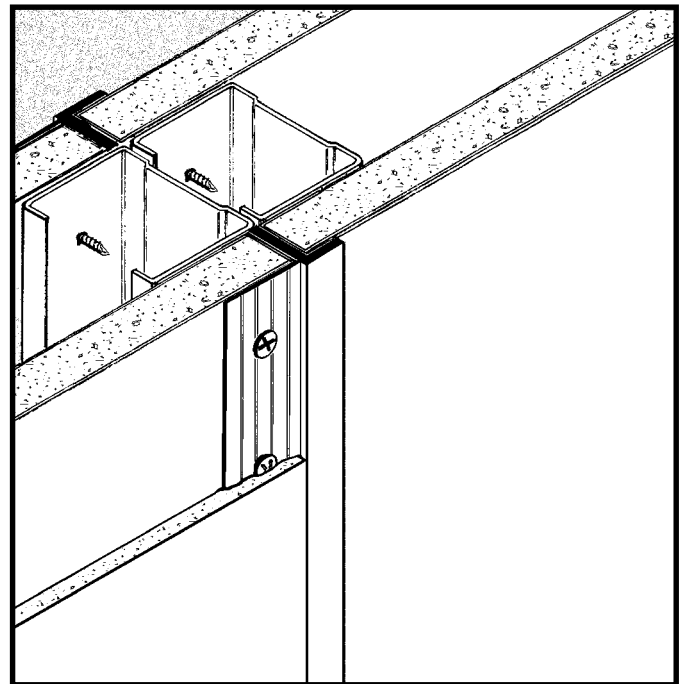

© 2003 Pittcon Industries

*West*

17070 Green Drive  
 City of Industry, CA 91745  
 Phone: (626) 839-9100  
 Fax: (626) 839-0258

3330 W. Flower Street  
 Phoenix, AZ 85017  
 Phone: (602) 233-9100  
 Fax: (602) 233-9400

**Pittcon  
 Industries**

DIVISION OF PITTCOON ARCHITECTURAL METALS, LLC

**800 637-7638**

*East*

6409 Rhode Island Ave.  
 Riverdale, MD 20737  
 Phone: (301) 927-1000  
 Fax: (301) 699-8690

# VPF-075

## EDGE TRIM

Specify as: Pittcon Plaster Molding

Model No. VPF-075

MATERIAL: Aluminum alloy.....6063 T5  
 Finish.....Clear Anodized  
 Thickness......050" nominal

Many optional finishes are available. Consult factory for pricing and availability. Finishes meet or exceed AAMA standards for scratches or blemishes.

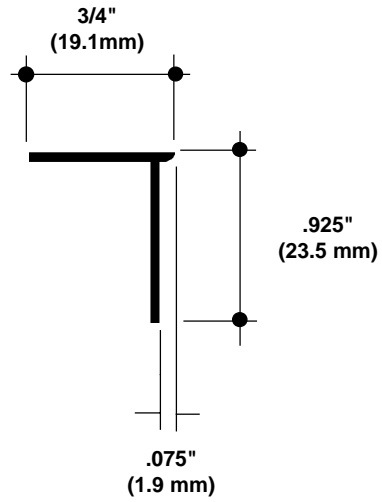

NO SCALE

TYPICAL SECTION

Model No.	Depth
VPF-075	3/4" (19.1mm)

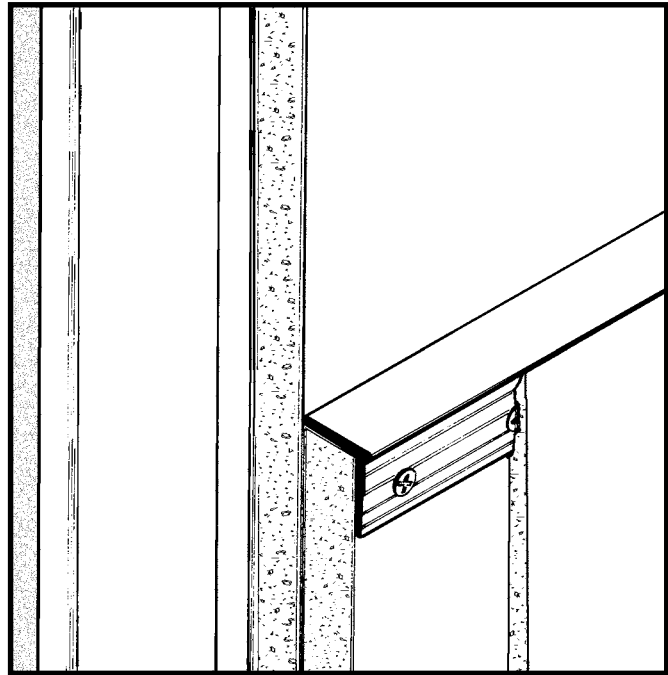

© 2003 Pittcon Industries

*West*

17070 Green Drive  
 City of Industry, CA 91745  
 Phone: (626) 839-9100  
 Fax: (626) 839-0258

3330 W. Flower Street  
 Phoenix, AZ 85017  
 Phone: (602) 233-9100  
 Fax: (602) 233-9400

**Pittcon Industries**

DIVISION OF PITTCOON ARCHITECTURAL METALS, LLC

**800 637-7638**

*East*

6409 Rhode Island Ave.  
 Riverdale, MD 20737  
 Phone: (301) 927-1000  
 Fax: (301) 699-8690

# VPFB 75-38/38

## REVEAL EDGE TRIM

Specify as: Pittcon Plaster Molding

Model No. VPFB 75-38/38

MATERIAL: Aluminum alloy.....6063 T5  
 Finish.....Clear Anodized  
 Thickness......050" nominal

Many optional finishes are available. Consult factory for pricing and availability. Finishes meet or exceed AAMA standards for scratches or blemishes.

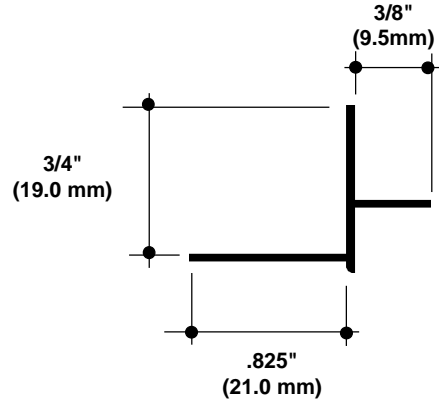

NO SCALE

TYPICAL SECTION

Model No.	Depth
VPFB 75-38/38	3/4" (19.1mm)

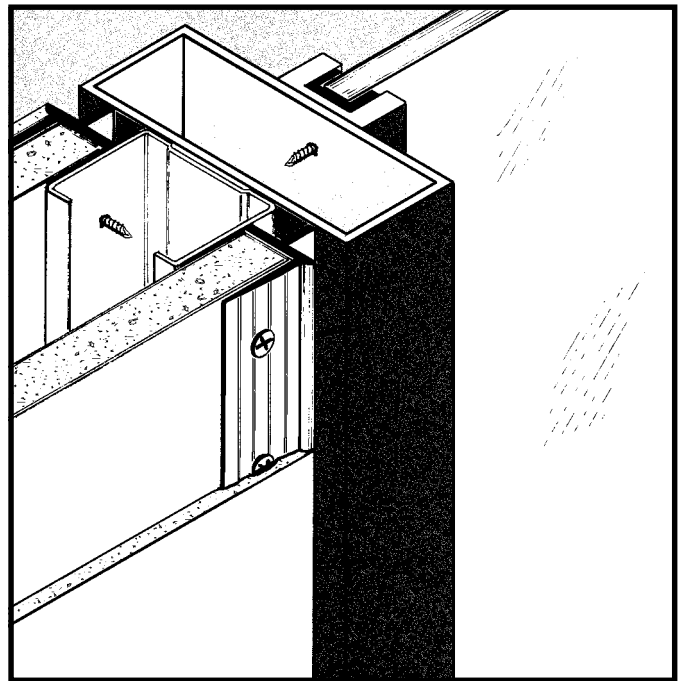

© 2003 Pittcon Industries

*West*

17070 Green Drive  
 City of Industry, CA 91745  
 Phone: (626) 839-9100  
 Fax: (626) 839-0258

3330 W. Flower Street  
 Phoenix, AZ 85017  
 Phone: (602) 233-9100  
 Fax: (602) 233-9400

**Pittcon  
 Industries**

DIVISION OF PITTCON ARCHITECTURAL METALS, LLC

**800 637-7638**

*East*

6409 Rhode Island Ave.  
 Riverdale, MD 20737  
 Phone: (301) 927-1000  
 Fax: (301) 699-8690

# VPJ-075

## 'J' CORNER REVEAL

Specify as: Pittcon Plaster Molding

Model No. VPJ-075

MATERIAL: Aluminum alloy.....6063 T5  
 Finish.....Clear Anodized  
 Thickness......050" nominal

Many optional finishes are available. Consult factory for pricing and availability. Finishes meet or exceed AAMA standards for scratches or blemishes.

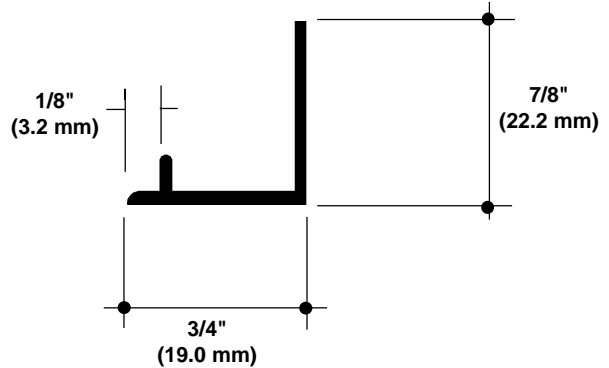

NO SCALE

TYPICAL SECTION

Model No.	Width
VPJ-075	3/4" (19.1mm)

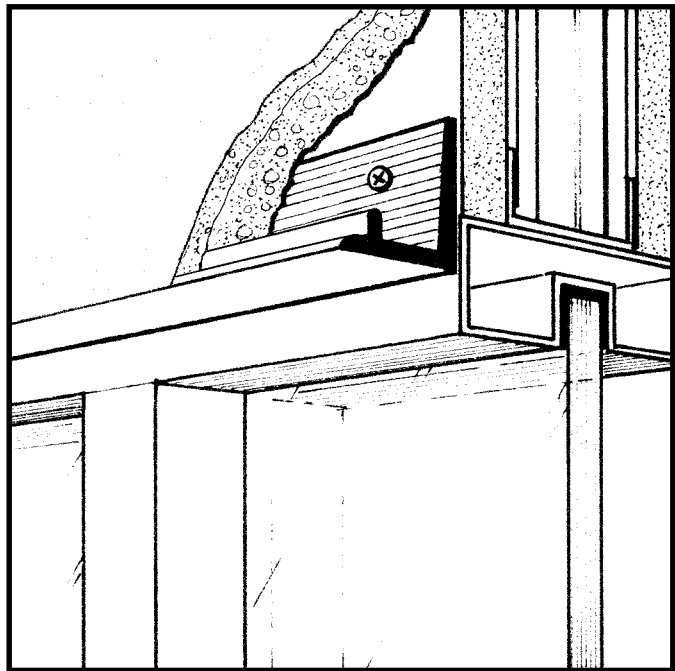

© 2003 Pittcon Industries

*West*

17070 Green Drive  
 City of Industry, CA 91745  
 Phone: (626) 839-9100  
 Fax: (626) 839-0258

3330 W. Flower Street  
 Phoenix, AZ 85017  
 Phone: (602) 233-9100  
 Fax: (602) 233-9400

**Pittcon Industries**

DIVISION OF PITTCOON ARCHITECTURAL METALS, LLC

**800 637-7638**

*East*

6409 Rhode Island Ave.  
 Riverdale, MD 20737  
 Phone: (301) 927-1000  
 Fax: (301) 699-8690