

# PCS SERIES CHANNEL SCREED

Specify as: **Pittcon Plaster Molding**

Model No. **PCS-xx-xxx**  
**PCS-xx-V-xxx** (vented)

MATERIAL: Aluminum alloy.....6063 T5  
Finish.....Clear Anodized  
Thickness......050" nominal

Many optional finishes are available. Consult factory for pricing and availability. Finishes meet or exceed AAMA standards for scratches or blemishes.

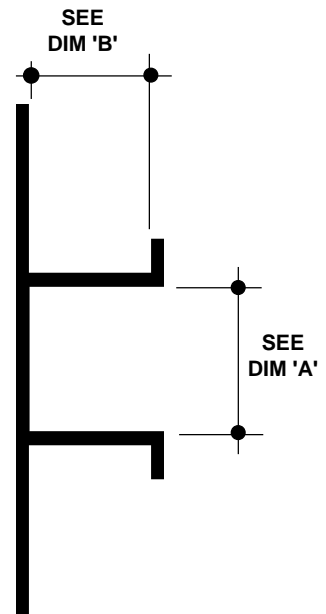

NO SCALE

TYPICAL SECTION

Model No.	Width-Dim 'A'	Depth-Dim 'B'
PCS-75-50	1/2" (12.7mm)	3/4" (19.1mm)
PCS-75-75	3/4" (19.1mm)	3/4" (19.1mm)
PCS-75-V-75	3/4" (19.1mm)	3/4" (19.1mm)
PCS-75-100	1" (25.1mm)	3/4" (19.1mm)
PCS-75-V-100	1" (25.1mm)	3/4" (19.1mm)
PCS-75-150	1-1/2" (38.1mm)	3/4" (19.1mm)
PCS-75-V-150	1-1/2" (38.1mm)	3/4" (19.1mm)
PCS-75-200	2" (50.8mm)	3/4" (19.1mm)
PCS-75-V-200	2" (50.8mm)	3/4" (19.1mm)
PCS-75-250	2-1/2" (63.5mm)	3/4" (19.1mm)
PCS-75-V-250	2-1/2" (63.5mm)	3/4" (19.1mm)
PCS-75-300	3" (76.2mm)	3/4" (19.1mm)
PCS-75-V-300	3" (76.2mm)	3/4" (19.1mm)
PCS-75-400	4" (101.6mm)	3/4" (19.1mm)
PCS-75-V-400	4" (101.6mm)	3/4" (19.1mm)
PCS-75-600	6" (152.4mm)	3/4" (19.1mm)
PCS-75-V-600	6" (152.4mm)	3/4" (19.1mm)
<hr/>		
PCS-100-75	3/4" (19.1mm)	1" (25.1mm)
PCS-100-V-75	3/4" (19.1mm)	1" (25.1mm)
PCS-100-100	1" (25.1mm)	1" (25.1mm)
PCS-100-V-100	1" (25.1mm)	1" (25.1mm)

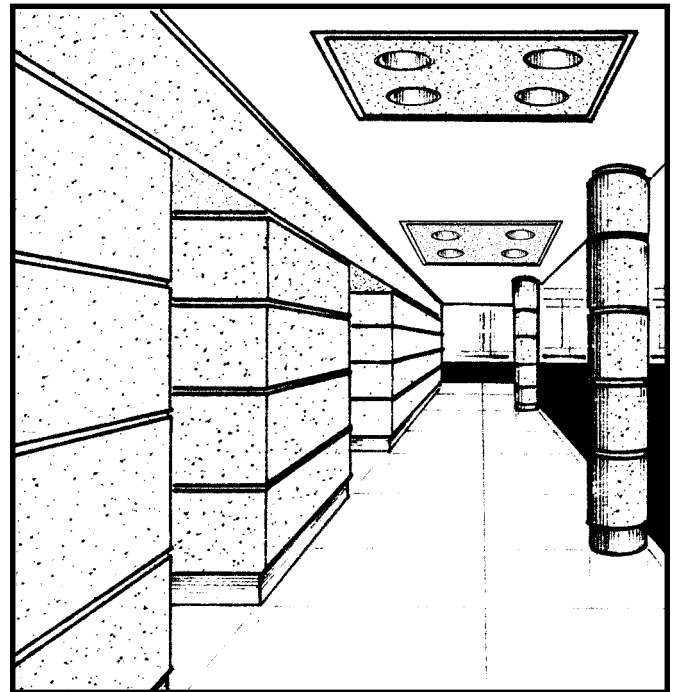

©2003 Pittcon Industries



17070 Green Drive  
City of Industry, CA 91745  
Phone: (626) 839-9100  
Fax: (626) 839-0258

3330 W. Flower Street  
Phoenix, AZ 85017  
Phone: (602) 233-9100  
Fax: (602) 233-9400



DIVISION OF PITTCOON ARCHITECTURAL METALS, LLC

800 637-7638



6409 Rhode Island Ave.  
Riverdale, MD 20737  
Phone: (301) 927-1000  
Fax: (301) 699-8690

# FPM SERIES

## 'F' MOLDING

Specify as: Pittcon Plaster Molding

Model No. FPM-xx-xxx  
FPM-xx-V-xxx (vented)

MATERIAL: Aluminum alloy.....6063 T5  
Finish.....Clear Anodized  
Thickness......050" nominal

Many optional finishes are available. Consult factory for pricing and availability. Finishes meet or exceed AAMA standards for scratches or blemishes.

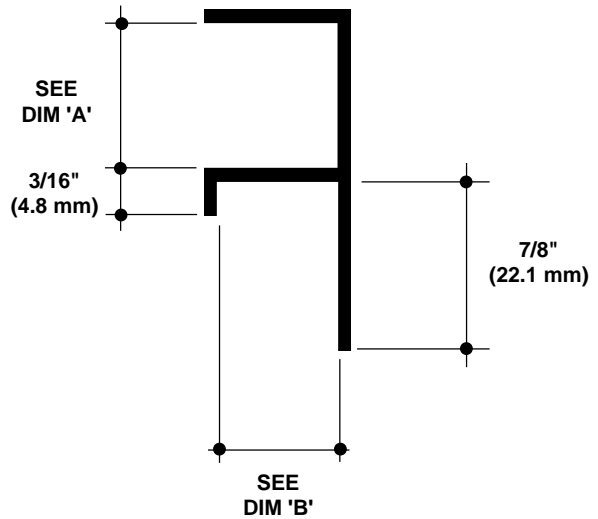

NO SCALE

TYPICAL SECTION

Model No.	Width-Dim 'A'	Depth-Dim 'B'
FPM-75-50	1/2" (12.7mm)	3/4" (19.1mm)
FPM-75-75	3/4" (19.1mm)	3/4" (19.1mm)
FPM-75-V-75	3/4" (19.1mm)	3/4" (19.1mm)
FPM-75-100	1" (25.1mm)	3/4" (19.1mm)
FPM-75-V-100	1" (25.1mm)	3/4" (19.1mm)
FPM-75-150	1-1/2" (38.1mm)	3/4" (19.1mm)
FPM-75-V-150	1-1/2" (38.1mm)	3/4" (19.1mm)
FPM-75-200	2" (50.8mm)	3/4" (19.1mm)
FPM-75-V-200	2" (50.8mm)	3/4" (19.1mm)
FPM-75-300	3" (76.2mm)	3/4" (19.1mm)
FPM-75-V-300	3" (76.2mm)	3/4" (19.1mm)
FPM-75-400	4" (101.6mm)	3/4" (19.1mm)
FPM-75-V-400	4" (101.6mm)	3/4" (19.1mm)
<hr/>		
FPM-100-75	3/4" (19.1mm)	1" (25.1mm)
FPM-100-V-75	3/4" (19.1mm)	1" (25.1mm)
FPM-100-100	1" (25.1mm)	1" (25.1mm)
FPM-100-V-100	1" (25.1mm)	1" (25.1mm)

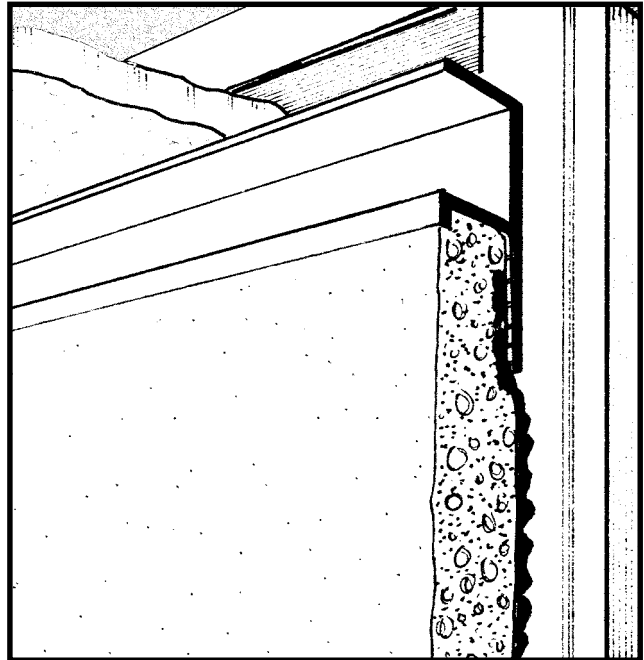

© 2003 Pittcon Industries



17070 Green Drive  
City of Industry, CA 91745  
Phone: (626) 839-9100  
Fax: (626) 839-0258

3330 W. Flower Street  
Phoenix, AZ 85017  
Phone: (602) 233-9100  
Fax: (602) 233-9400



DIVISION OF PITTCOON ARCHITECTURAL METALS, LLC

800 637-7638



6409 Rhode Island Ave.  
Riverdale, MD 20737  
Phone: (301) 927-1000  
Fax: (301) 699-8690

# TRM SERIES 'T' MOLDING

Specify as: **Pittcon Plaster Molding**

Model No. **TRM-xx-xxx**  
**TRM-xx-V-xxx (vented)**

MATERIAL: Aluminum alloy.....6063 T5  
Finish.....Clear Anodized  
Thickness......050" nominal

Many optional finishes are available. Consult factory for pricing and availability. Finishes meet or exceed AAMA standards for scratches or blemishes.

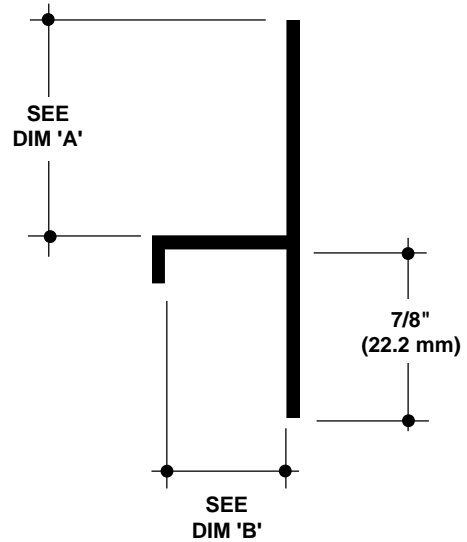

NO SCALE

TYPICAL SECTION

Model No.	Width-Dim 'A'	Depth-Dim 'B'
TRM-75-75	3/4" (19.1mm)	3/4" (19.1mm)
TRM-75-V-75	3/4" (19.1mm)	3/4" (19.1mm)
TRM-75-100	1" (25.4mm)	3/4" (19.1mm)
TRM-75-V-100	1" (25.4mm)	3/4" (19.1mm)
TRM-75-150	1-1/2" (38.1mm)	3/4" (19.1mm)
TRM-75-V-150	1-1/2" (38.1mm)	3/4" (19.1mm)
TRM-75-200	2" (50.8mm)	3/4" (19.1mm)
TRM-75-V-200	2" (50.8mm)	3/4" (19.1mm)
TRM-75-300	3" (76.2mm)	3/4" (19.1mm)
TRM-75-V-300	3" (76.2mm)	3/4" (19.1mm)
TRM-75-400	4" (101.6mm)	3/4" (19.1mm)
TRM-75-V-400	4" (101.6mm)	3/4" (19.1mm)
<hr/>		
TRM-100-75	3/4" (19.1mm)	1" (25.1mm)
TRM-100-V-75	3/4" (19.1mm)	1" (25.1mm)
TRM-100-100	1" (25.1mm)	1" (25.1mm)
TRM-100-V-100	1" (25.1mm)	1" (25.1mm)

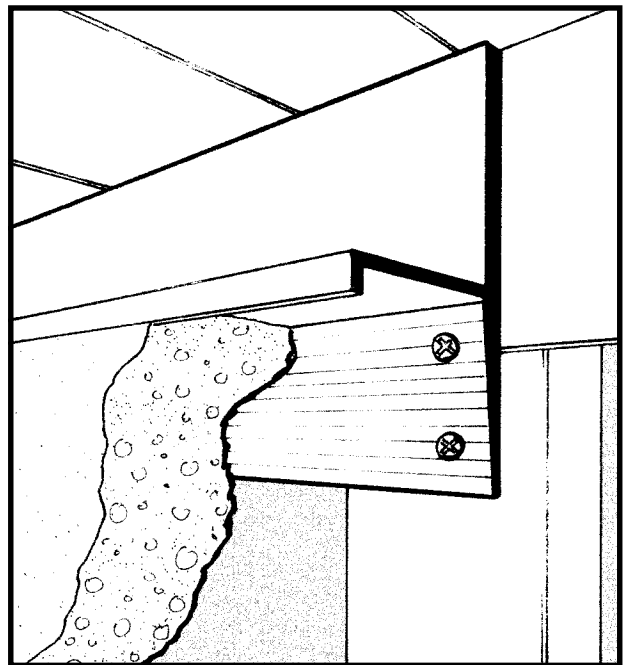

©2003 Pittcon Industries

*West*

17070 Green Drive  
City of Industry, CA 91745  
Phone: (626) 839-9100  
Fax: (626) 839-0258

3330 W. Flower Street  
Phoenix, AZ 85017  
Phone: (602) 233-9100  
Fax: (602) 233-9400

**Pittcon  
Industries**

DIVISION OF PITTCOON ARCHITECTURAL METALS, LLC

**800 637-7638**

*East*

6409 Rhode Island Ave.  
Riverdale, MD 20737  
Phone: (301) 927-1000  
Fax: (301) 699-8690

# DS SERIES DRIP SCREED

Specify as: Pittcon Plaster Molding

Model No. DS-xx-875  
DS-xx-V-875 (vented)

MATERIAL: Aluminum alloy.....6063 T5  
Finish.....Clear Anodized  
Thickness......050" nominal

Many optional finishes are available. Consult factory for pricing and availability. Finishes meet or exceed AAMA standards for scratches or blemishes.

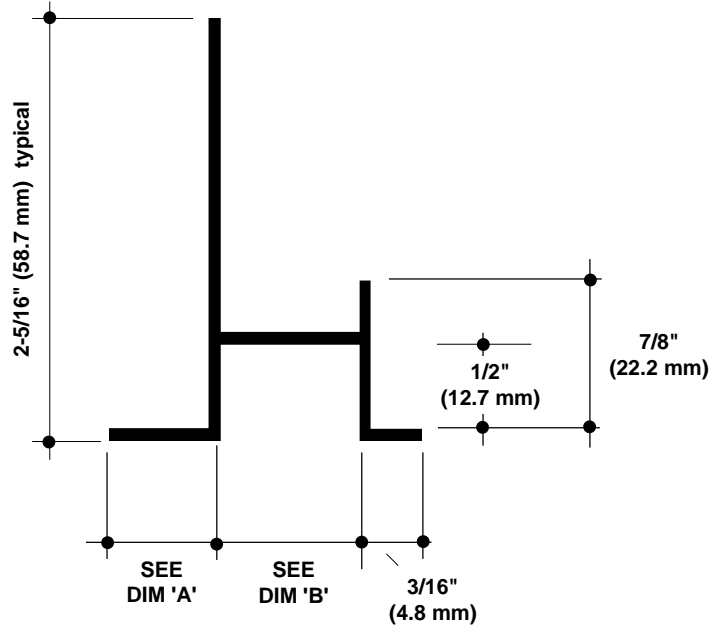

NO SCALE

TYPICAL SECTION

Model No.	Width-Dim 'A'	Reveal Width-Dim 'B'
DS-50-875	1/2" (22.2mm)	7/8" (22.2mm)
DS-50-V-875	1/2" (22.2mm)	7/8" (22.2mm)
DS-675-875	5/8" (19.7mm)	7/8" (22.2mm)
DS-675-V-875	5/8" (19.7mm)	7/8" (22.2mm)
DS-875-875	7/8" (22.2mm)	7/8" (22.2mm)
DS-875-V-875	7/8" (22.2mm)	7/8" (22.2mm)
DS-875-200	7/8" (22.2mm)	2" (50.8mm)
DS-875-V-200	7/8" (22.2mm)	2" (50.8mm)
DS-875-300	7/8" (22.2mm)	3" (76.2mm)
DS-875-V-300	7/8" (22.2mm)	3" (76.2 mm)

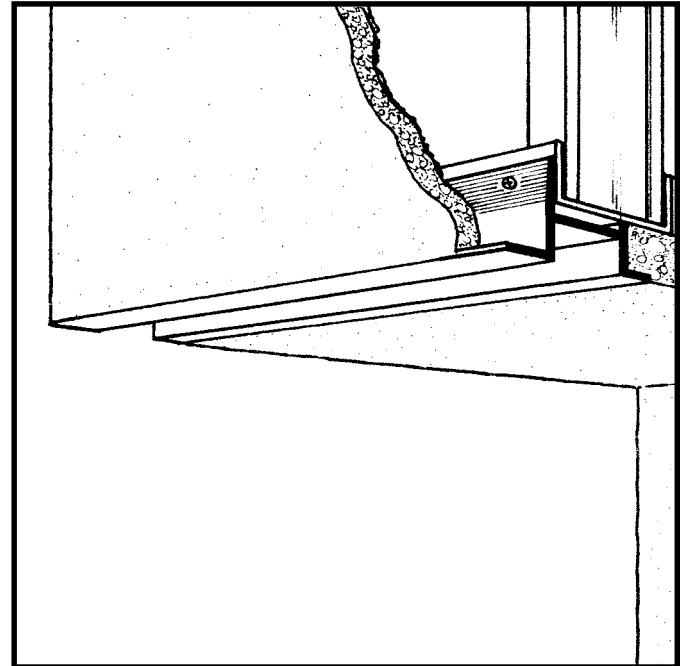

© 2003 Pittcon Industries

*West*

17070 Green Drive  
City of Industry, CA 91745  
Phone: (626) 839-9100  
Fax: (626) 839-0258

3330 W. Flower Street  
Phoenix, AZ 85017  
Phone: (602) 233-9100  
Fax: (602) 233-9400

**Pittcon  
Industries**

DIVISION OF PITTCOON ARCHITECTURAL METALS, LLC

800 637-7638

*East*

6409 Rhode Island Ave.  
Riverdale, MD 20737  
Phone: (301) 927-1000  
Fax: (301) 699-8690

# JPM SERIES 'J' MOLDINGS

Specify as: Pittcon Plaster Molding

Model No. JPM-xx

MATERIAL: Aluminum alloy.....6063 T5  
 Finish.....Clear Anodized  
 Thickness......050" nominal

Many optional finishes are available. Consult factory for pricing and availability. Finishes meet or exceed AAMA standards for scratches or blemishes.

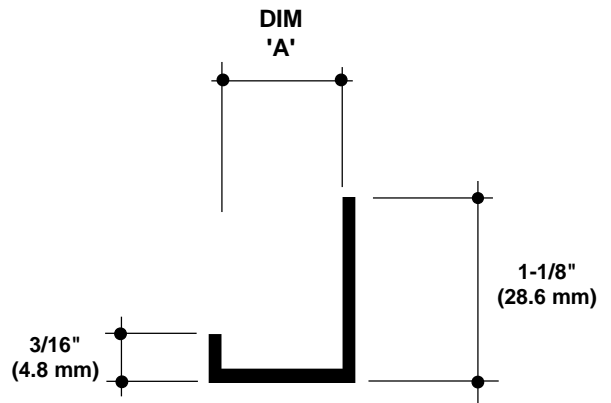

NO SCALE

TYPICAL SECTION

Model No.	Depth-Dim 'A'
JPM-75	3/4" (19.1mm)
JPM-100	1" (25.4mm)

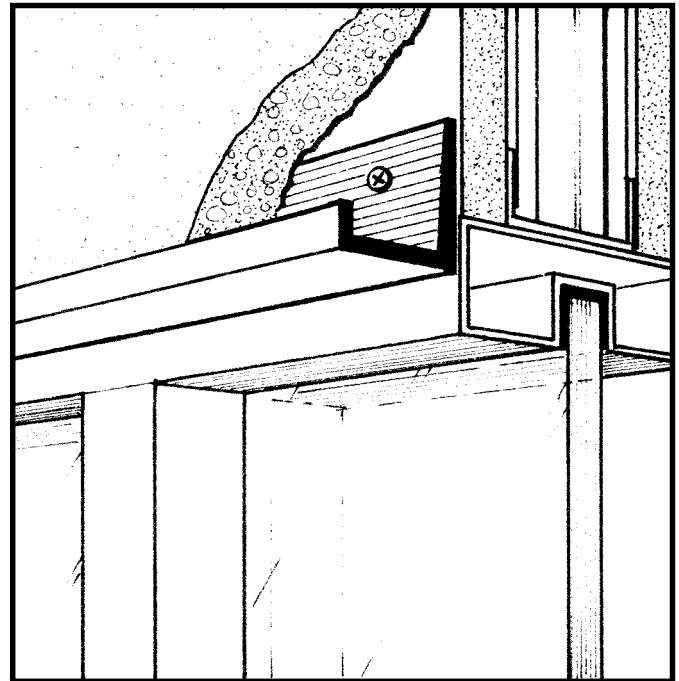

©2003 Pittcon Industries



17070 Green Drive  
 City of Industry, CA 91745  
 Phone: (626) 839-9100  
 Fax: (626) 839-0258

3330 W. Flower Street  
 Phoenix, AZ 85017  
 Phone: (602) 233-9100  
 Fax: (602) 233-9400



DIVISION OF PITTCOON ARCHITECTURAL METALS, LLC

800 637-7638



6409 Rhode Island Ave.  
 Riverdale, MD 20737  
 Phone: (301) 927-1000  
 Fax: (301) 699-8690

# XPM SERIES CORNER MOLD

Specify as: Pittcon Plaster Molding

Model No. XPM-75-75

MATERIAL: Aluminum alloy.....6063 T5  
 Finish.....Clear Anodized  
 Thickness......050" nominal

Many optional finishes are available. Consult factory for pricing and availability. Finishes meet or exceed AAMA standards for scratches or blemishes.

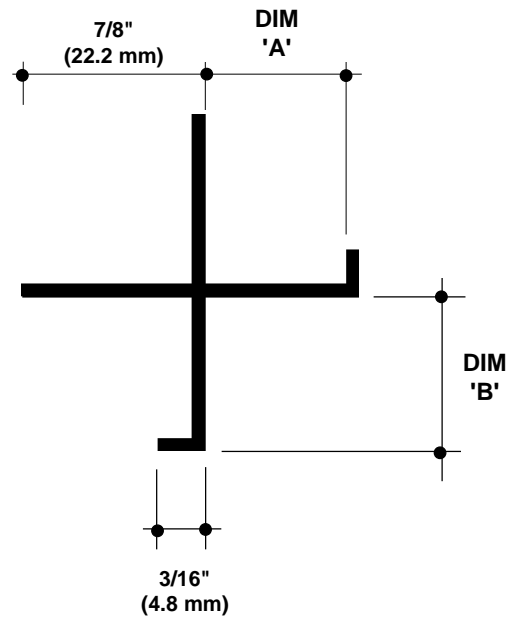

NO SCALE

TYPICAL SECTION

Model No.	Width-Dim 'A'	Depth-Dim 'B'
XPM 50-50	1/2" (12.7mm)	1/2" (12.7mm)
XPM 625-625	5/8" (15.9mm)	5/8" (15.9mm)
XPM 75-75	3/4" (19.1mm)	3/4" (19.1mm)

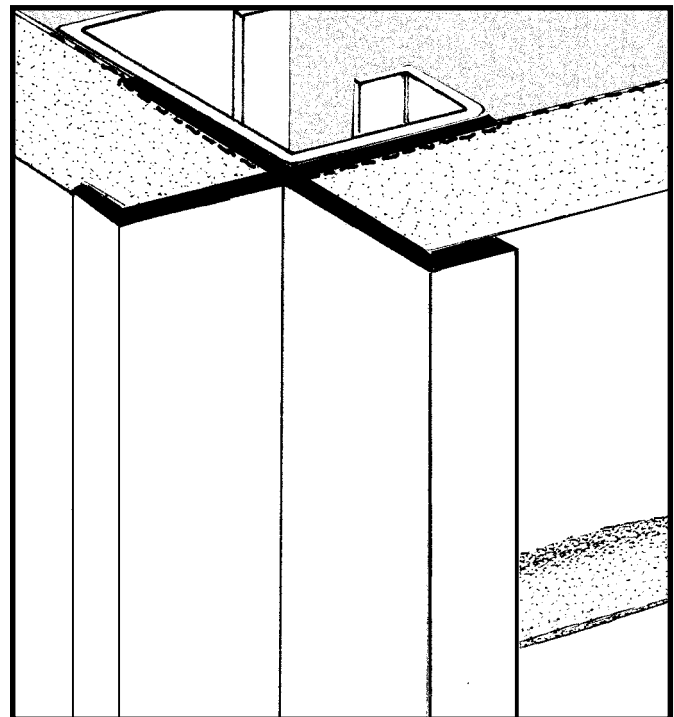

© 2003 Pittcon Industries



17070 Green Drive  
 City of Industry, CA 91745  
 Phone: (626) 839-9100  
 Fax: (626) 839-0258

3330 W. Flower Street  
 Phoenix, AZ 85017  
 Phone: (602) 233-9100  
 Fax: (602) 233-9400

**Pittcon  
 Industries**

DIVISION OF PITTCO ARCHITECTURAL METALS, LLC

**800 637-7638**



6409 Rhode Island Ave.  
 Riverdale, MD 20737  
 Phone: (301) 927-1000  
 Fax: (301) 699-8690

# PCS-2PC. SERIES

## TWO PIECE CONTROL SCREED

Specify as: Pittcon Plaster Molding

Model No. PCS-75-xx 2PC.

MATERIAL: Aluminum alloy.....6063 T5  
 Finish.....Clear Anodized  
 Thickness......050" nominal

Many optional finishes are available. Consult factory for pricing and availability. Finishes meet or exceed AAMA standards for scratches or blemishes.

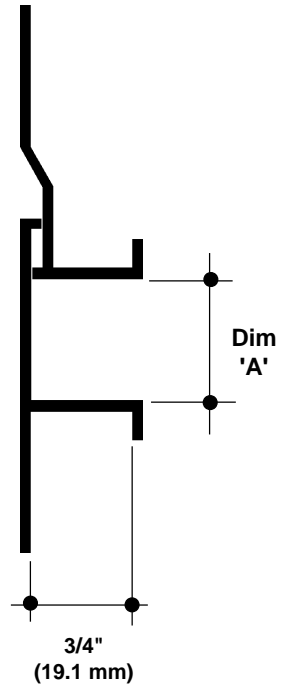

+/- 1/4" MOVEMENT

NO SCALE

TYPICAL SECTION

Model No.	Width -Dim 'A'	Depth
PCS-75-25 2PC.	1/4" (6.4mm)	3/4" (19.1mm)
PCS-75-50 2PC.	1/2" (12.7mm)	3/4" (19.1mm)
PCS-75-75 2PC.	3/4" (19.1mm)	3/4" (19.1mm)
PCS-75-100 2PC.	1" (25.4mm)	3/4" (19.1mm)
PCS-75-150 2PC.	1-1/2" (38.1mm)	3/4" (19.1mm)
PCS-75-200 2PC.	2" (50.8mm)	3/4" (19.1mm)

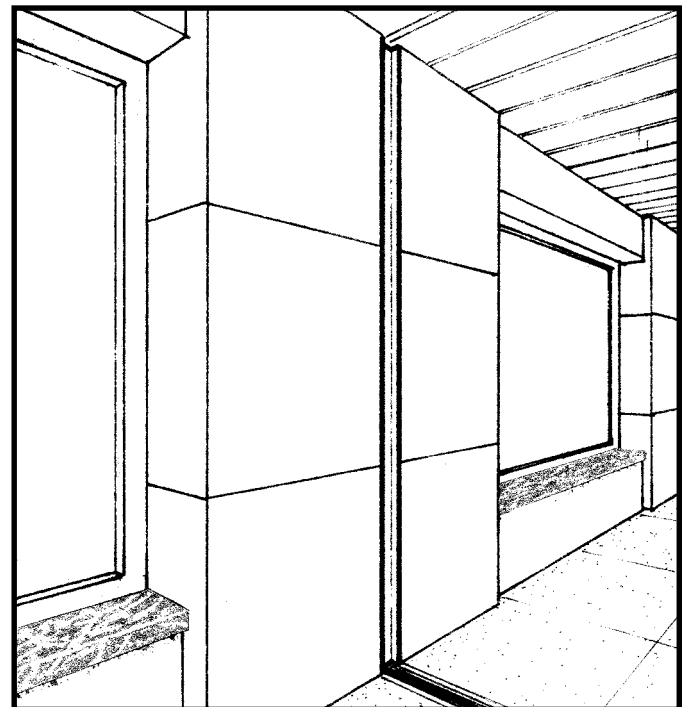
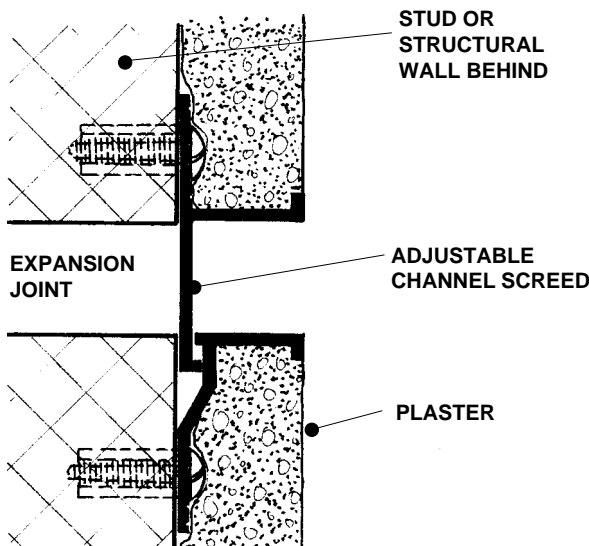

©2003 Pittcon Industries

*West*

17070 Green Drive  
 City of Industry, CA 91745  
 Phone: (626) 839-9100  
 Fax: (626) 839-0258

3330 W. Flower Street  
 Phoenix, AZ 85017  
 Phone: (602) 233-9100  
 Fax: (602) 233-9400

**Pittcon Industries**

DIVISION OF PITTCON ARCHITECTURAL METALS, LLC

800 637-7638

*East*

6409 Rhode Island Ave.  
 Riverdale, MD 20737  
 Phone: (301) 927-1000  
 Fax: (301) 699-8690

# PCM-75 CORNER MOLD

Specify as: Pittcon Plaster Molding

Model No. PCM-75

MATERIAL: Aluminum alloy.....6063 T5  
 Finish.....Clear Anodized  
 Thickness......050" nominal

Many optional finishes are available. Consult factory for pricing and availability. Finishes meet or exceed AAMA standards for scratches or blemishes.

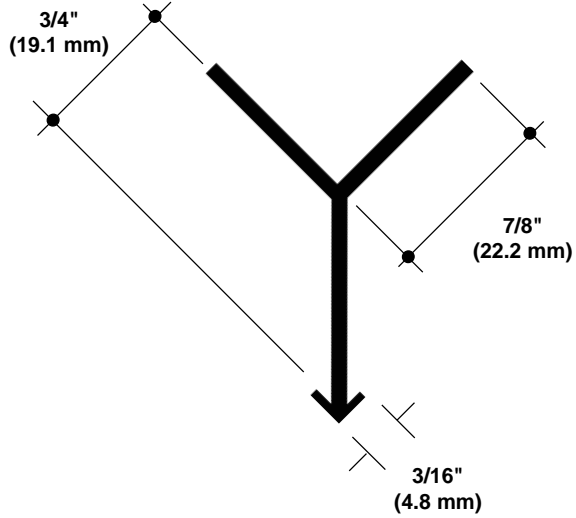

NO SCALE

TYPICAL SECTION

Model No.	Depth
PCM-75	3/4" (19.1mm)

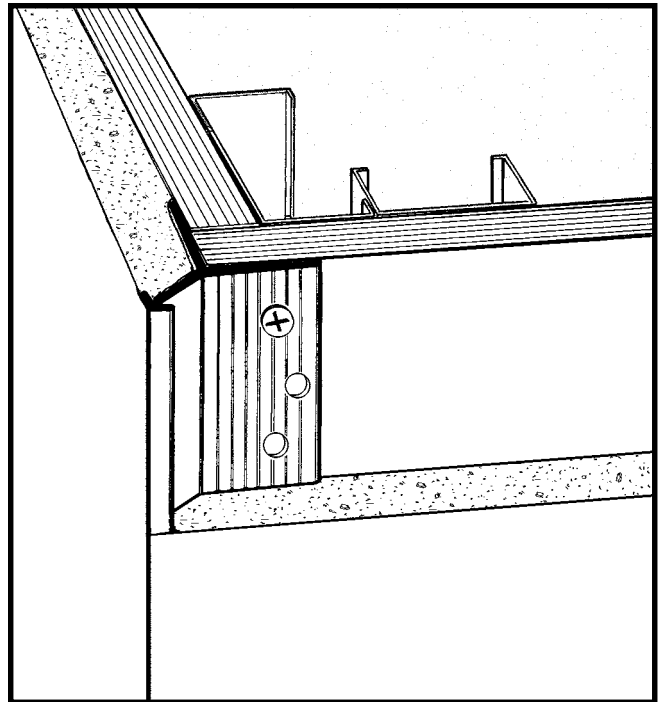

© 2003 Pittcon Industries



17070 Green Drive  
 City of Industry, CA 91745  
 Phone: (626) 839-9100  
 Fax: (626) 839-0258

3330 W. Flower Street  
 Phoenix, AZ 85017  
 Phone: (602) 233-9100  
 Fax: (602) 233-9400

**Pittcon  
 Industries**

DIVISION OF PITTCOON ARCHITECTURAL METALS, LLC

**800 637-7638**



6409 Rhode Island Ave.  
 Riverdale, MD 20737  
 Phone: (301) 927-1000  
 Fax: (301) 699-8690

# WRM-75-75

## 'W' REVEAL MOLDING

Specify as: Pittcon Plaster Molding

Model No. WRM-75-75  
WRM-75-V-75 (vented)

MATERIAL: Aluminum alloy.....6063 T5  
Finish.....Clear Anodized  
Thickness......050" nominal

Many optional finishes are available. Consult factory for pricing and availability. Finishes meet or exceed AAMA standards for scratches or blemishes.

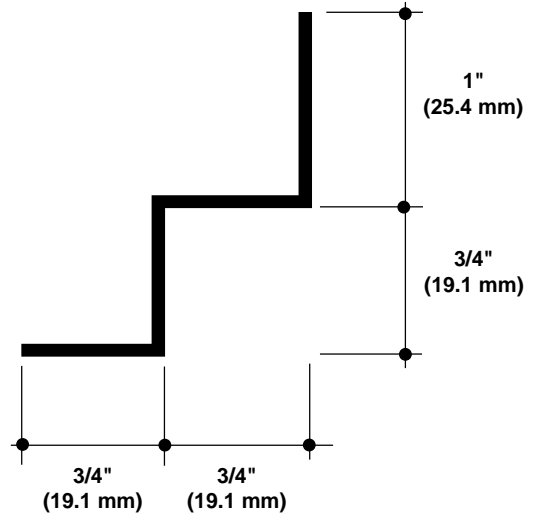

NO SCALE

TYPICAL SECTION

Model No.	Width	Depth
WRM-75-75	3/4" (19.1mm)	3/4" (19.1mm)
WRM-75-V-75	3/4" (19.1mm)	3/4" (19.1mm)

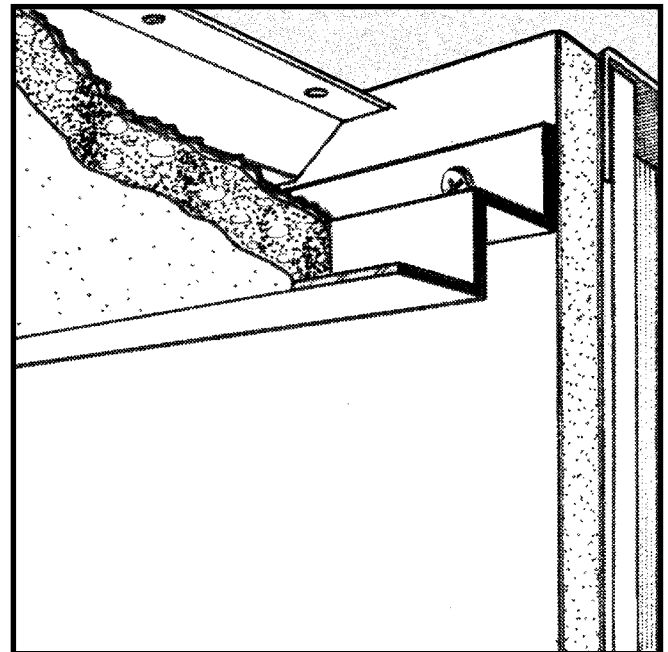

©2003 Pittcon Industries



17070 Green Drive  
City of Industry, CA 91745  
Phone: (626) 839-9100  
Fax: (626) 839-0258

3330 W. Flower Street  
Phoenix, AZ 85017  
Phone: (602) 233-9100  
Fax: (602) 233-9400

**Pittcon Industries**

DIVISION OF PITTCOON ARCHITECTURAL METALS, LLC

**800 637-7638**



6409 Rhode Island Ave.  
Riverdale, MD 20737  
Phone: (301) 927-1000  
Fax: (301) 699-8690

# PRZ-75-75

## SOFFIT/WALL REVEAL

Specify as: Pittcon Plaster Molding

Model No. PRZ-75-75  
PRZ-75-V-75 (vented)

MATERIAL: Aluminum alloy.....6063 T5  
Finish.....Clear Anodized  
Thickness......050" nominal

Many optional finishes are available. Consult factory for pricing and availability. Finishes meet or exceed AAMA standards for scratches or blemishes.

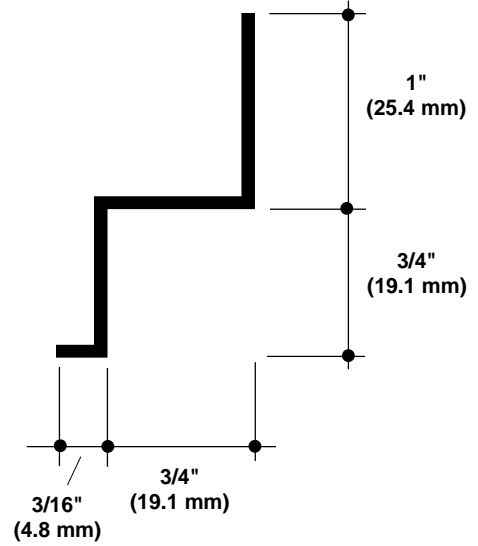

NO SCALE

TYPICAL SECTION

Model No.	Width	Depth
PRZ-75-75	3/4" (19.1mm)	3/4" (19.1mm)
PRZ-75-V-75	3/4" (19.1mm)	3/4" (19.1mm)

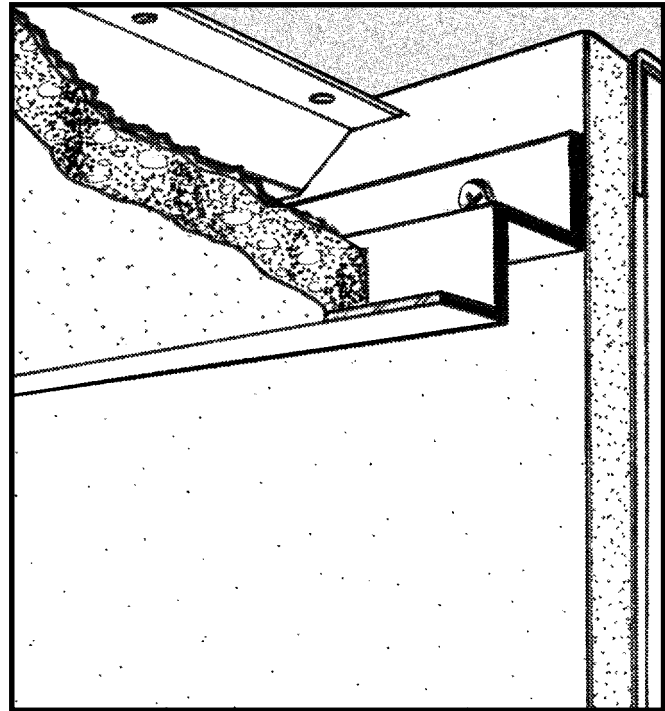

© 2003 Pittcon Industries

*West*

17070 Green Drive  
City of Industry, CA 91745  
Phone: (626) 839-9100  
Fax: (626) 839-0258

3330 W. Flower Street  
Phoenix, AZ 85017  
Phone: (602) 233-9100  
Fax: (602) 233-9400

**Pittcon Industries**

DIVISION OF PITTCOON ARCHITECTURAL METALS, LLC

800 637-7638

*East*

6409 Rhode Island Ave.  
Riverdale, MD 20737  
Phone: (301) 927-1000  
Fax: (301) 699-8690

# PCS 75-25/25

## CHANNEL SCREED

Specify as: Pittcon Plaster Molding

Model No. PCS-75-25/25

MATERIAL: Aluminum alloy.....6063 T5  
 Finish.....Clear Anodized  
 Thickness......050" nominal

Many optional finishes are available. Consult factory for pricing and availability. Finishes meet or exceed AAMA standards for scratches or blemishes.

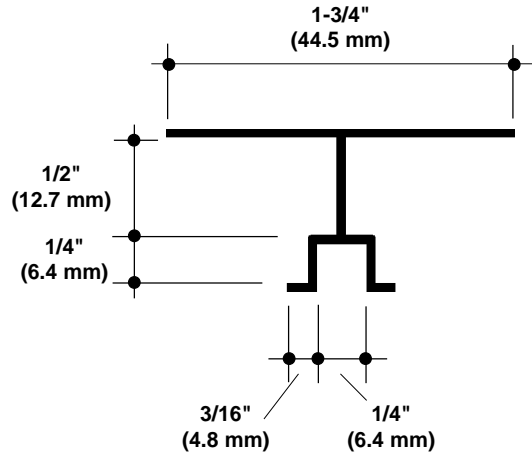

NO SCALE

TYPICAL SECTION

Model No.	Width	Depth
PCS-75-25/25	1/4" (6.4mm)	3/4" (19.1mm)

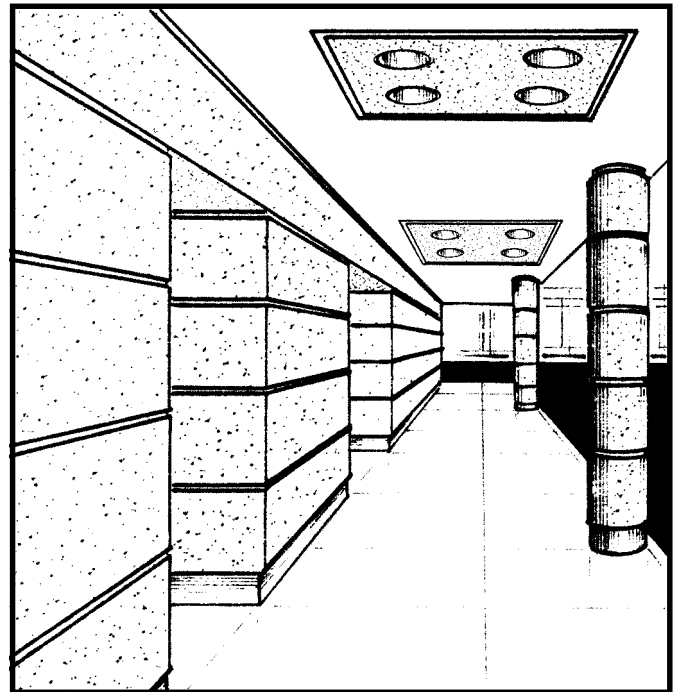

©2003 Pittcon Industries



17070 Green Drive  
 City of Industry, CA 91745  
 Phone: (626) 839-9100  
 Fax: (626) 839-0258

3330 W. Flower Street  
 Phoenix, AZ 85017  
 Phone: (602) 233-9100  
 Fax: (602) 233-9400

**Pittcon Industries**

DIVISION OF PITTCOON ARCHITECTURAL METALS, LLC

**800 637-7638**



6409 Rhode Island Ave.  
 Riverdale, MD 20737  
 Phone: (301) 927-1000  
 Fax: (301) 699-8690

# FCM-75

## FASCIA CORNER

Specify as: Pittcon Plaster Molding

Model No. FCM-75

MATERIAL: Aluminum alloy.....6063 T5  
 Finish.....Clear Anodized  
 Thickness......050" nominal

Many optional finishes are available. Consult factory for pricing and availability. Finishes meet or exceed AAMA standards for scratches or blemishes.

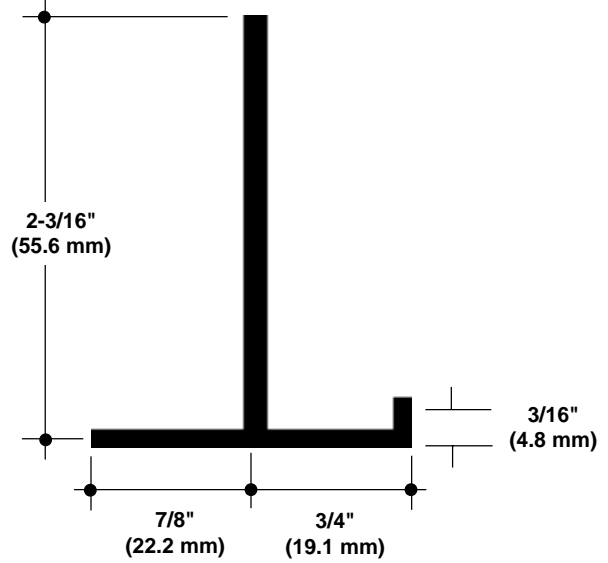

NO SCALE

TYPICAL SECTION

Model No.	Width	Depth
-----------	-------	-------

FCM-75	1-5/8 (41.3mm)	3/4" (19.1mm)
--------	----------------	---------------

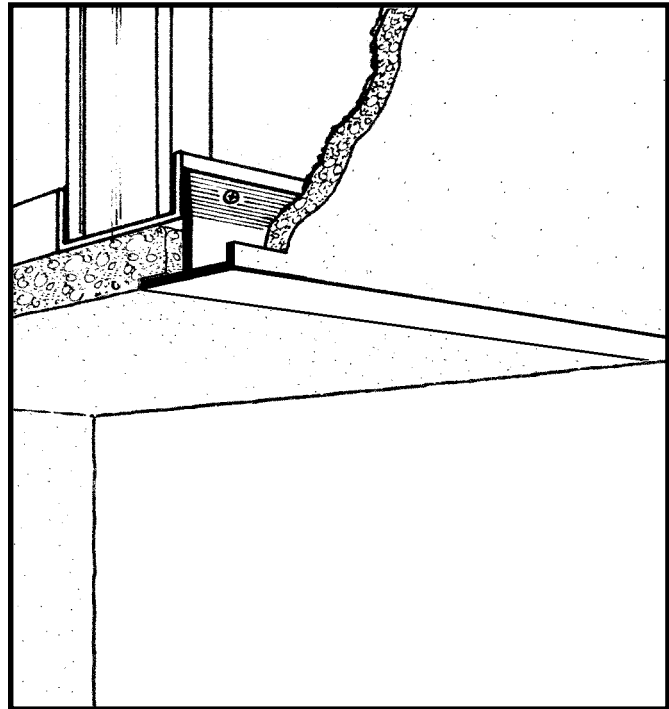

© 2003 Pittcon Industries



17070 Green Drive  
 City of Industry, CA 91745  
 Phone: (626) 839-9100  
 Fax: (626) 839-0258

3330 W. Flower Street  
 Phoenix, AZ 85017  
 Phone: (602) 233-9100  
 Fax: (602) 233-9400



DIVISION OF PITTCOON ARCHITECTURAL METALS, LLC

800 637-7638



6409 Rhode Island Ave.  
 Riverdale, MD 20737  
 Phone: (301) 927-1000  
 Fax: (301) 699-8690

# WPM-75-300

## SOFFIT REVEAL

Specify as: Pittcon Plaster Molding

Model No. **WPM-75-300**  
**WPM-75-V-300 (vented)**

MATERIAL: Aluminum alloy.....6063 T5  
 Finish.....Clear Anodized  
 Thickness......050" nominal

Many optional finishes are available. Consult factory for pricing and availability. Finishes meet or exceed AAMA standards for scratches or blemishes.

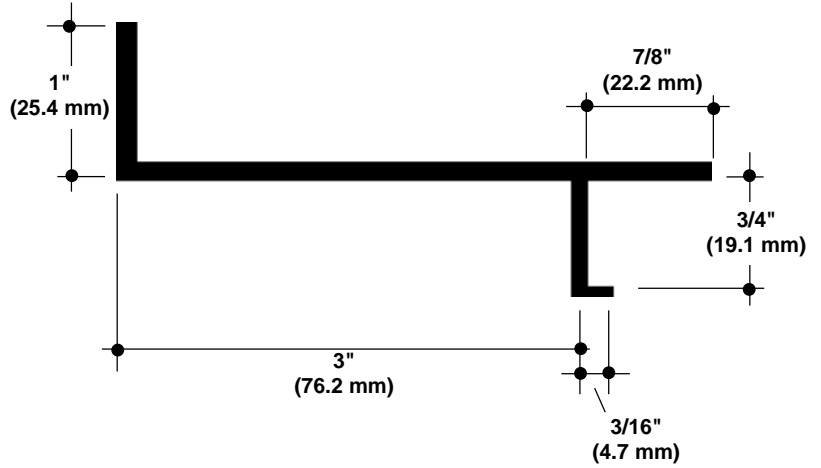

NO SCALE

TYPICAL SECTION

Model No.	Width	Depth
WPM-75-300	3" (76.2mm)	3/4" (19.1mm)
WPM-75-V-300	3" (76.2mm)	3/4" (19.1mm)

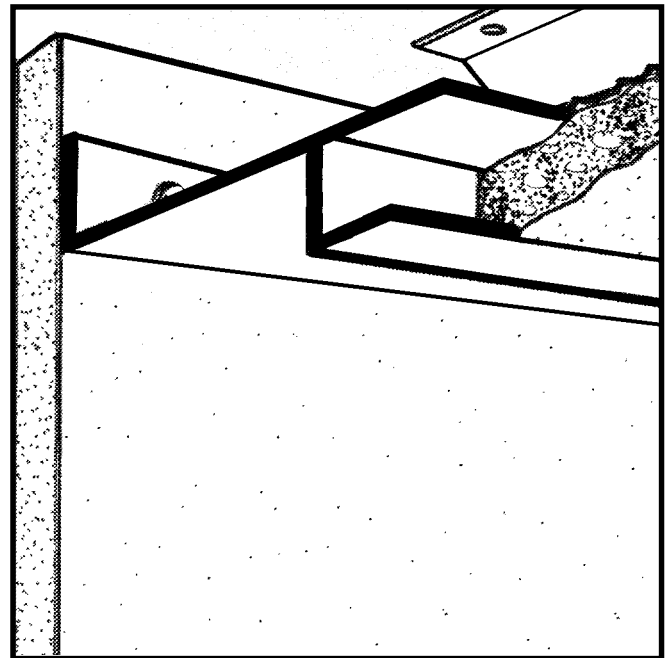

©2003 Pittcon Industries



17070 Green Drive  
 City of Industry, CA 91745  
 Phone: (626) 839-9100  
 Fax: (626) 839-0258

3330 W. Flower Street  
 Phoenix, AZ 85017  
 Phone: (602) 233-9100  
 Fax: (602) 233-9400



DIVISION OF PITTCOON ARCHITECTURAL METALS, LLC

800 637-7638



6409 Rhode Island Ave.  
 Riverdale, MD 20737  
 Phone: (301) 927-1000  
 Fax: (301) 699-8690

# XCM-50

## 'X' CORNER REVEAL

Specify as: Pittcon Plaster Molding

Model No. XCM-50

MATERIAL: Aluminum alloy.....6063 T5  
 Finish.....Clear Anodized  
 Thickness......050" nominal

Many optional finishes are available. Consult factory for pricing and availability. Finishes meet or exceed AAMA standards for scratches or blemishes.

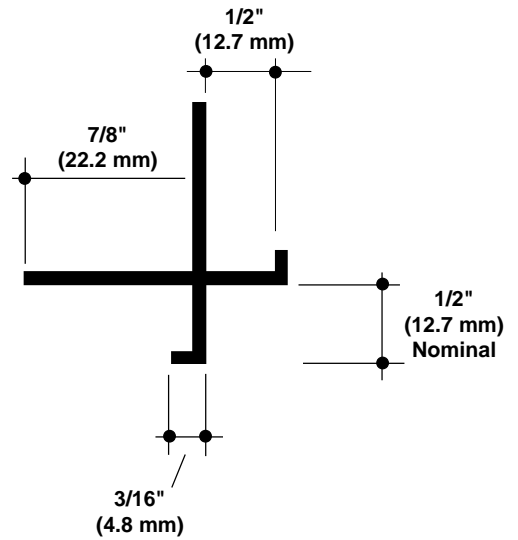

NO SCALE

TYPICAL SECTION

Model No.	Width	Depth
-----------	-------	-------

XCM-50	1/2" (12.7mm)	1/2" (12.7mm)
--------	---------------	---------------

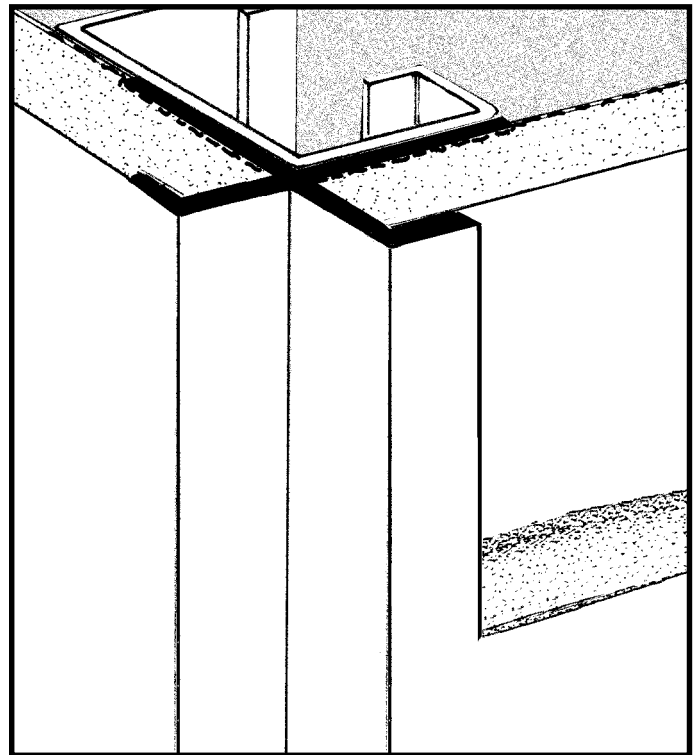

©2003 Pittcon Industries



17070 Green Drive  
 City of Industry, CA 91745  
 Phone: (626) 839-9100  
 Fax: (626) 839-0258

3330 W. Flower Street  
 Phoenix, AZ 85017  
 Phone: (602) 233-9100  
 Fax: (602) 233-9400



DIVISION OF PITTCOON ARCHITECTURAL METALS, LLC

800 637-7638



6409 Rhode Island Ave.  
 Riverdale, MD 20737  
 Phone: (301) 927-1000  
 Fax: (301) 699-8690

# WS-875

## WEEP SCREED

Specify as: Pittcon Plaster Molding

Model No. WS-875

MATERIAL: PVC.....050" Thick  
Color.....Grey

Meets ASTM-A525, A-527 & A-568.

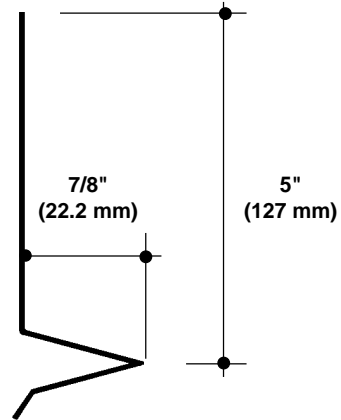

**THIS ITEM HAS BEEN DISCONTINUED**

NO SCALE

TYPICAL SECTION

Model No.	Ground Depth Dim 'A'
WS-875	7/8" (22.2mm)

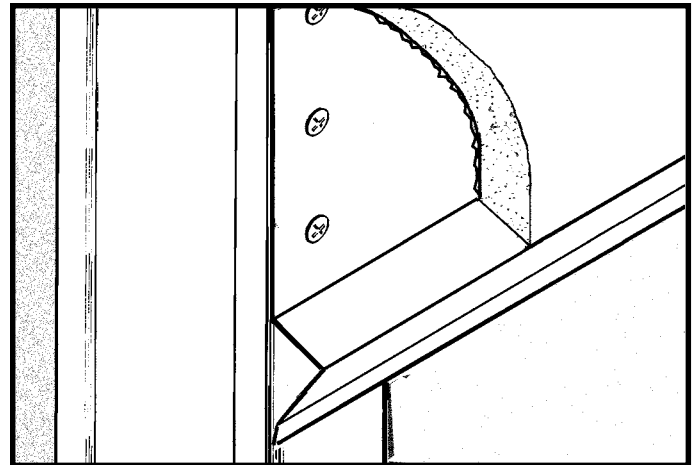

**THIS ITEM HAS BEEN DISCONTINUED**

© 2003 Pittcon Industries



17070 Green Drive  
City of Industry, CA 91745  
Phone: (626) 839-9100  
Fax: (626) 839-0258

3330 W. Flower Street  
Phoenix, AZ 85017  
Phone: (602) 233-9100  
Fax: (602) 233-9400



DIVISION OF PITTCOON ARCHITECTURAL METALS, LLC

800 637-7638



6409 Rhode Island Ave.  
Riverdale, MD 20737  
Phone: (301) 927-1000  
Fax: (301) 699-8690