

# A20-13-11

REV. 7/06

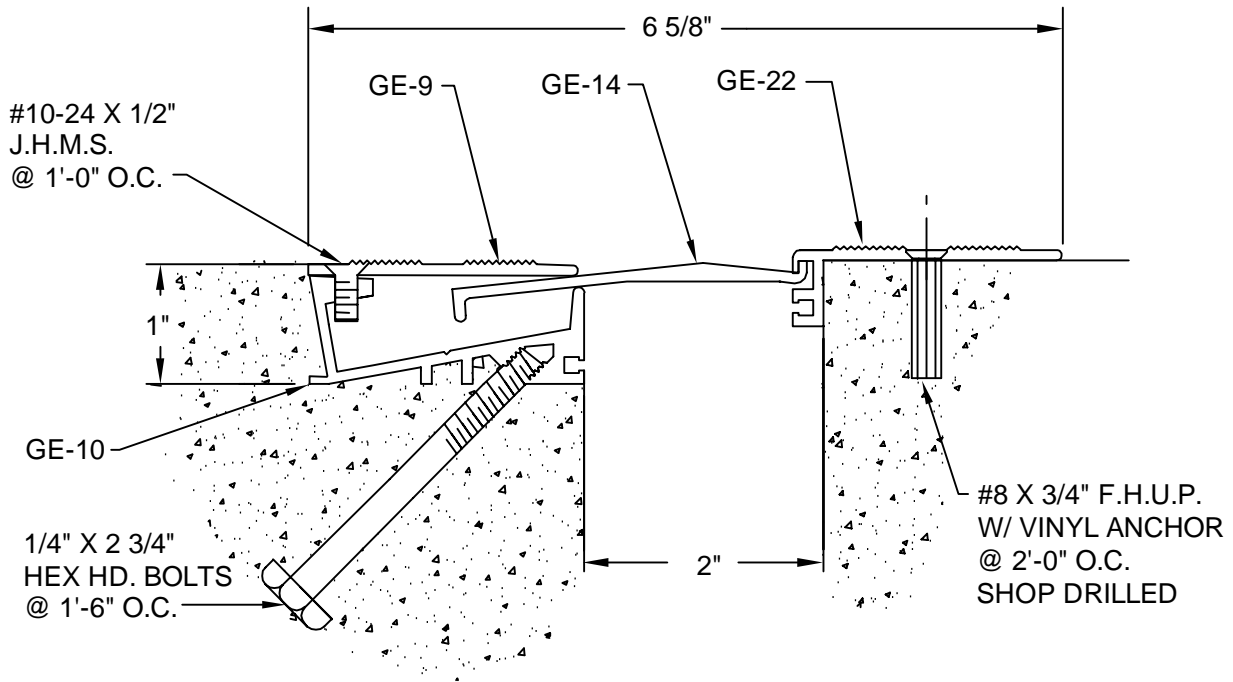

DESCRIPTION: FLOOR-TO-FLOOR  
 ALUMINUM: 6063-T5 EXTRUSION  
 EXPOSED FINISH: MILL  
 ZINC CHROMATE AREAS IN CONTACT W/ WET CEMENT  
 ALLOWABLE LOAD: 1748 LB/LF @ MAX. OPENING  
 MOVEMENT: +/- 50% JOINT WIDTH  
 STOCK LENGTHS: 20'-0"

CUSTOMER:		
PROJECT:		
LOCATION:		
ARCHITECT:		
CONTRACTOR:		
NOTE:		
JOB NO.:	DATE:	SCALE: (NTS)

LENGTH:	QTY:	COLOR/FINISH:



**ARCHITECTURAL ART MFG., INC.**  
 6409 RHODE ISLAND AVE. RIVERDALE, MD 20737

