

# A15-35-11

REV. 7/06

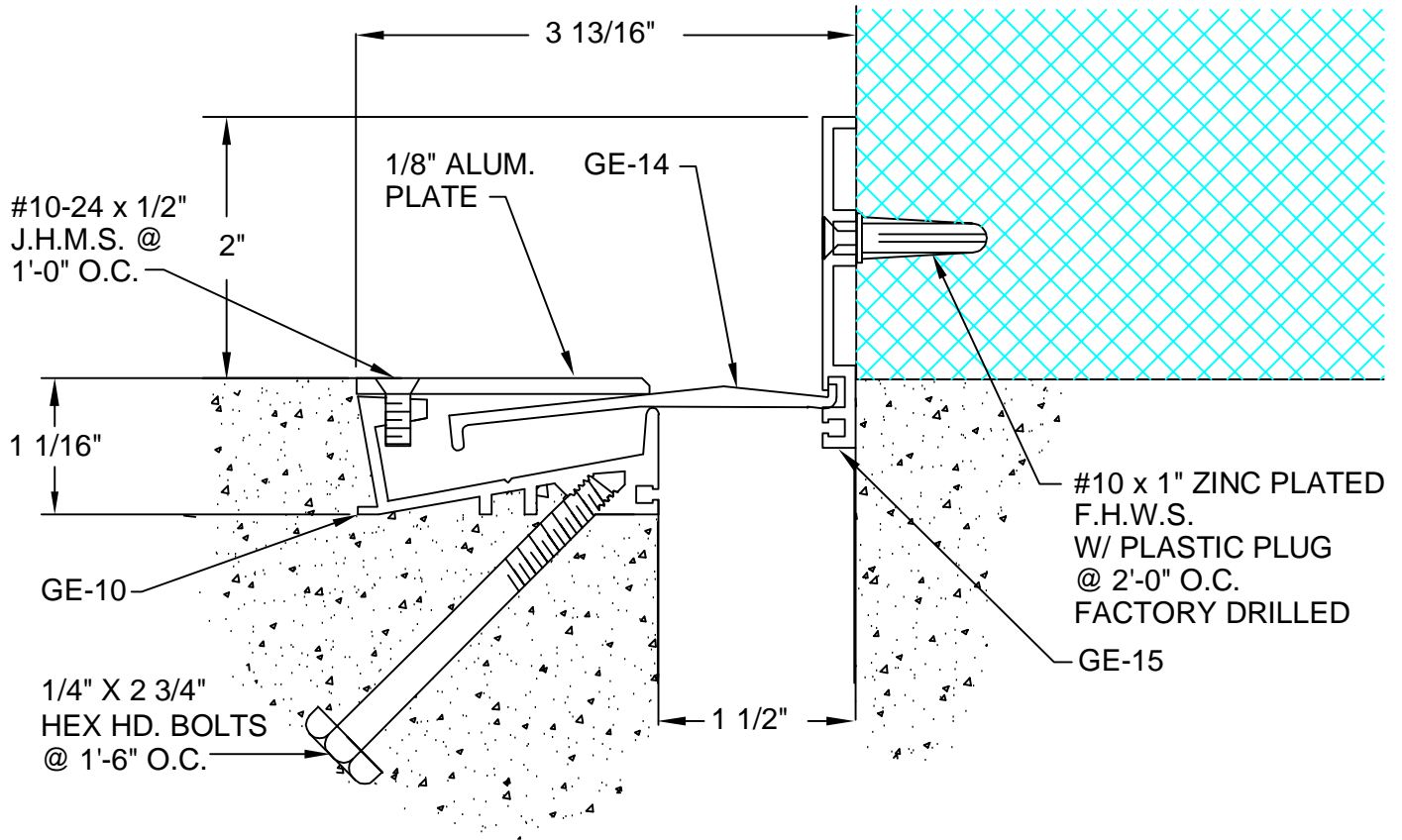

DESCRIPTION: FLOOR-TO-WALL  
 ALUMINUM: 6063-T5 EXTRUSION, 6061-T6 PLATE  
 EXPOSED FINISH: MILL  
 ZINC CHROMATE AREAS IN CONTACT W/ WET CEMENT  
 ALLOWABLE LOAD: 4208 LB/LF @ MAX. OPENING  
 MOVEMENT: +/- 50% JOINT WIDTH  
 STOCK LENGTHS: 10'-0"

CUSTOMER:		
PROJECT:		
LOCATION:		
ARCHITECT:		
CONTRACTOR:		
NOTE:		
JOB NO.:	DATE:	SCALE: (NTS)

LENGTH:	QTY:	COLOR/FINISH: