

A10-15-11

REV. 7/06

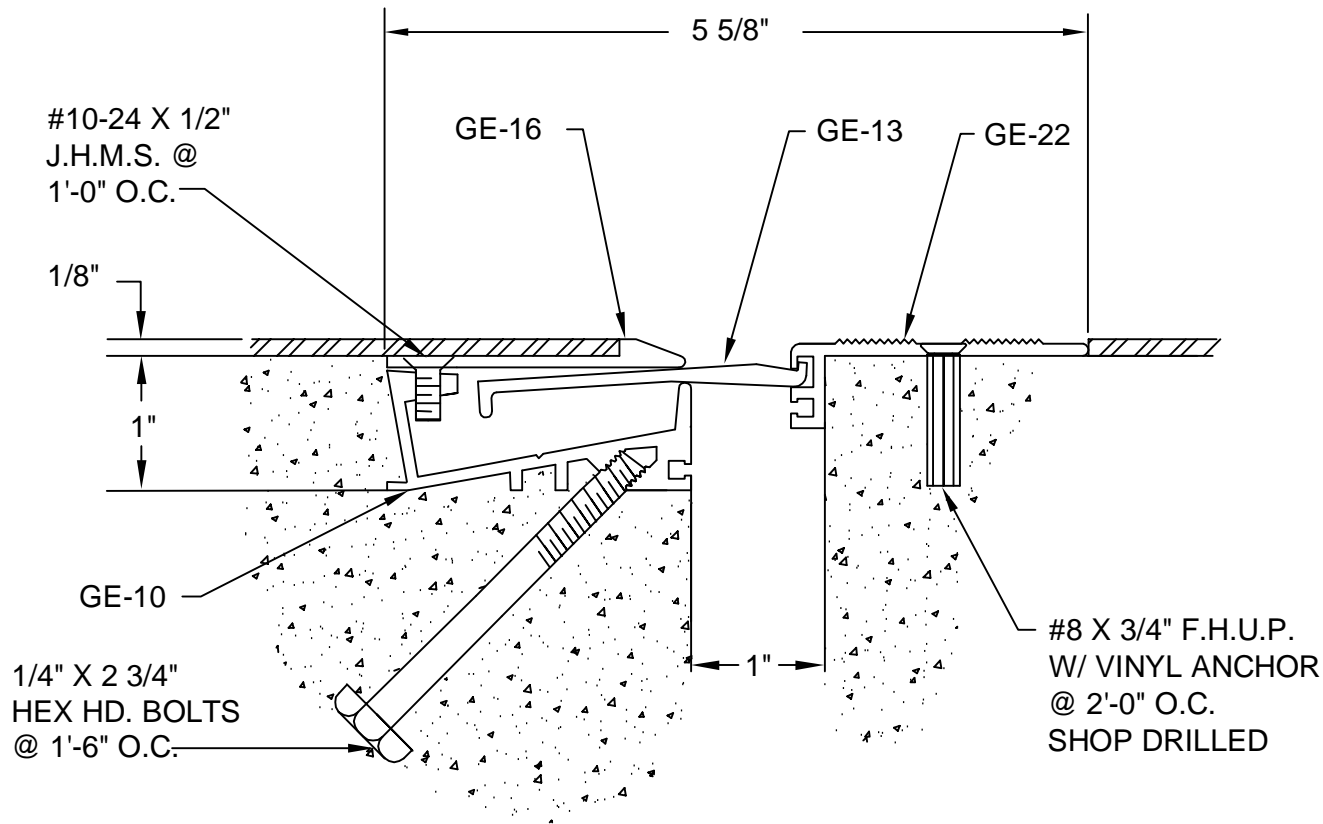

DESCRIPTION: FLOOR-TO-FLOOR
 ALUMINUM: 6063-T5 EXTRUSION
 EXPOSED FINISH: MILL
 ZINC CHROMATE AREAS IN CONTACT W/ WET CEMENT
 ALLOWABLE LOAD: 1748 LB/LF @ MAX. OPENING
 MOVEMENT: +/-50% JOINT WIDTH
 STOCK LENGTHS: 20'-0"

CUSTOMER:		
PROJECT:		
LOCATION:		
ARCHITECT:		
CONTRACTOR:		
NOTE:		
JOB NO.:	DATE:	SCALE: (NTS)

LENGTH:	QTY:	COLOR/FINISH: