

# A10-11-31

REV. 7/06

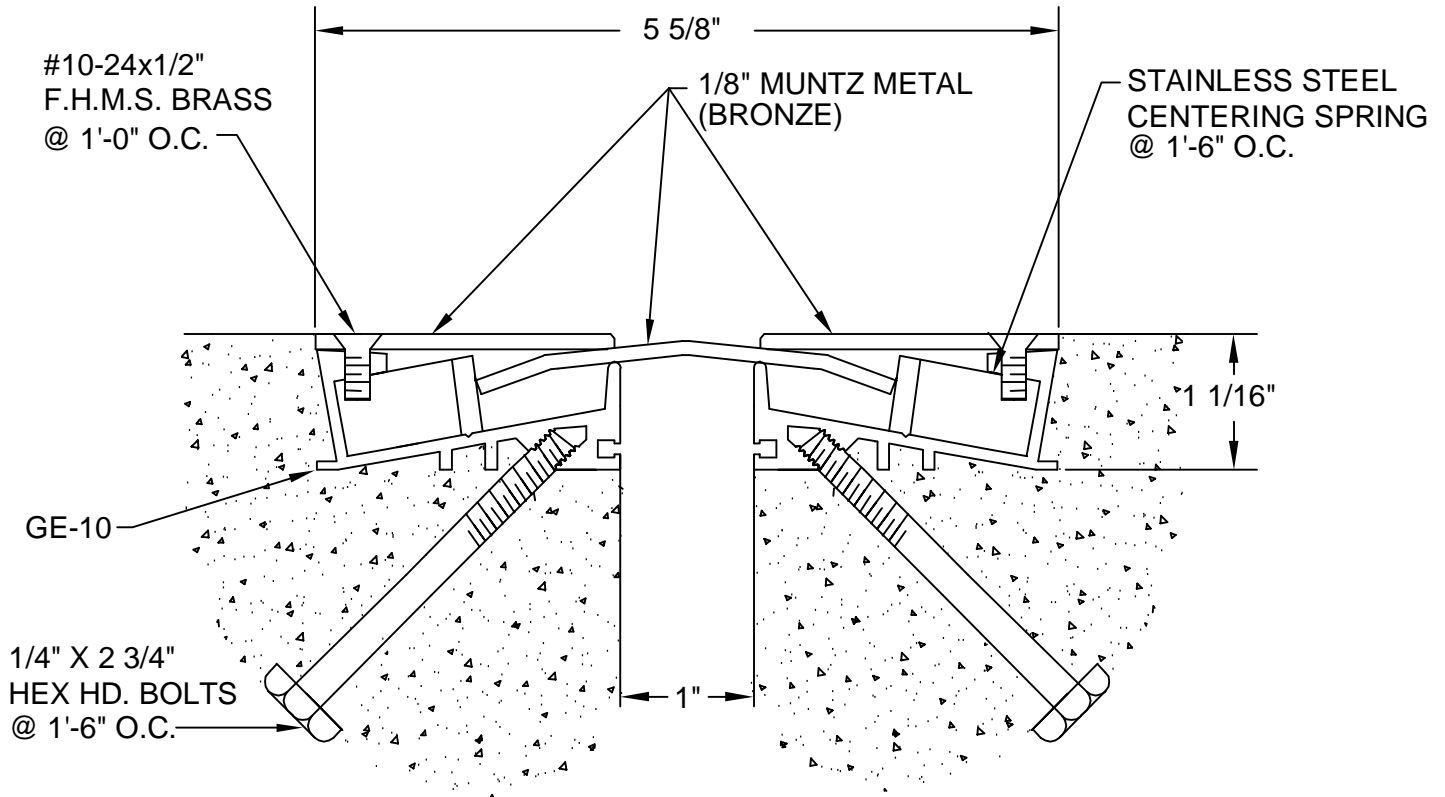

DESCRIPTION: FLOOR-TO-FLOOR  
 ALUMINUM: 6063-T5 EXTRUSION  
 BRONZE: 280 ALLOY MUNTZ METAL  
 EXPOSED FINISH: #3 SATIN  
 ZINC CHROMATE AREAS IN CONTACT W/ WET CEMENT  
 ALLOWABLE LOAD: 1875 LB/LF @ MAX. OPENING  
 MOVEMENT: +/- 100% JOINT WIDTH  
 STOCK LENGTHS: 10'-0"

CUSTOMER:		
PROJECT:		
LOCATION:		
ARCHITECT:		
CONTRACTOR:		
NOTE:		
JOB NO.:	DATE:	SCALE: (NTS)

LENGTH:	QTY:	COLOR/FINISH: